

# PhysicsByAaryan

CSIR NET . GATE . JEST . BARC - Physics

## Superconductivity - CSIR NET Physics PYQs

Solid State Physics . All PYQs (2015-2025) with answer key

**6 questions . Answer key included**

---

[www.physicsbyaaryan.com](http://www.physicsbyaaryan.com) . [www.csirnetphysics.com](http://www.csirnetphysics.com)

Contact: 9501976811

**Q1. [June 2015] . 5.0 marks**

Solid State Physics &gt; Superconductivity

CSIR NET	2015 June	5 M
----------	-----------	-----

The critical magnetic fields of a superconductor at temperatures 4 K and 8 K are 11 mA/m and 5.5 mA/m respectively. The transition temperature is approximately

1. 8.4 K
2. 10.6 K
3. 12.9 K
4. 15.0 K

**Q2. [Dec 2019] . 5.0 marks**

Solid State Physics &gt; Superconductivity

CSIR NET	2019 Dec	5M
----------	----------	----

In the AC Josephson effect, a supercurrent flows across two superconductors separated by a thin insulating layer and kept at an electric potential difference  $\Delta V$ . The angular frequency of the resultant supercurrent is given by

1.  $\frac{2e\Delta V}{\hbar}$
2.  $\frac{e\Delta V}{\hbar}$
3.  $\frac{e\Delta V}{\pi\hbar}$
4.  $\frac{e\Delta V}{2\pi\hbar}$

## Q3. [June 2021] . 5.0 marks

Solid State Physics &gt; Superconductivity

CSIR NET	2021 June	5M
----------	-----------	----

To measure the height  $h$  of a column of liquid helium in a container, a constant current  $I$  is sent through an NbTi wire of length  $l$ , as shown in the figure. The normal state resistance of the NbTi wire is  $R$ . If the superconducting transition temperature of NbTi is  $\approx 10\text{K}$ , then the measured voltage  $V(h)$  is best described by the expression

1.  $IR \left( \frac{1}{2} - \frac{2h}{l} \right)$
2.  $IR \left( 1 - \frac{h}{l} \right)$
3.  $IR \left( \frac{1}{2} - \frac{h}{l} \right)$
4.  $IR \left( 1 - \frac{2h}{l} \right)$

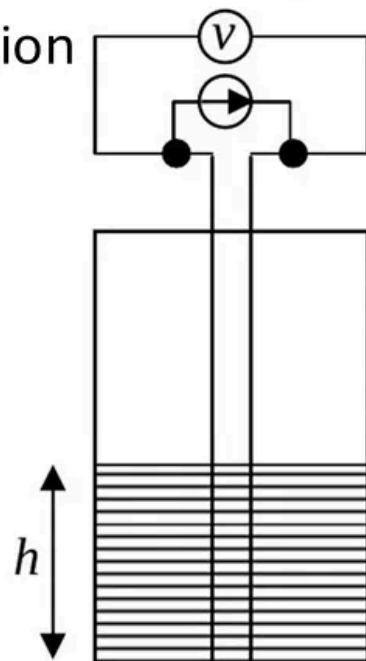

**Q4. [June 2021] . 5.0 marks**

Solid State Physics &gt; Superconductivity

CSIR NET	2021 June	5M
----------	-----------	----

Lead is superconducting below 7 K and has a critical magnetic field  $800 \times 10^{-4}$  tesla close to 0 K. At 2 K the critical current that flows through a long lead wire of radius 5 mm is closest to

1. 1760 A
2. 1670 A
3. 1950 A
4. 1840 A

**Q5. [Dec 2024] . 5.0 marks**

Solid State Physics > Superconductivity

CSIR NET	2024 Dec	5M
----------	----------	----

Magnetization  $M$  as a function of applied magnetic field  $H$  for two different solid samples at temperature  $T$  are shown below. These samples are known to be superconducting below their respective critical temperatures ( $T_C$ ).

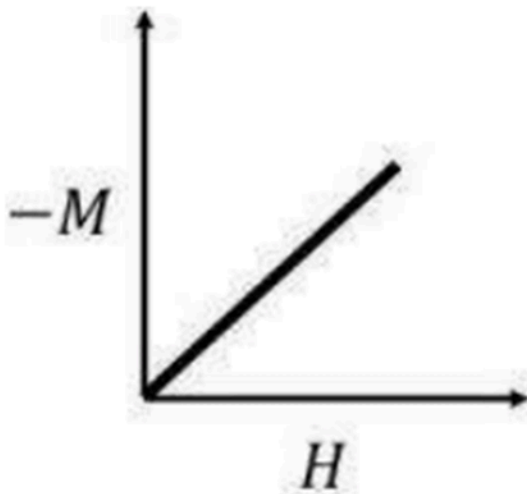

Fig. 1

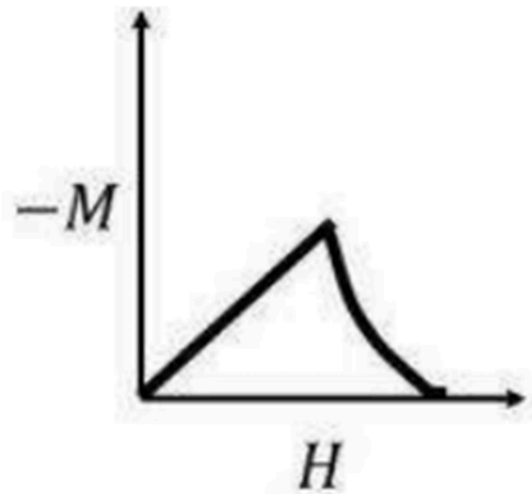

Fig. 2

The correct set of statements is

1. Fig. 1: Type I superconductor above  $T_C$ ;  
 Fig. 2: Type II superconductor below  $T_C$  and upto upper critical field;
2. Fig. 1: Type II superconductor below  $T_C$  and upto upper critical field;  
 Fig. 2: Type II superconductor below  $T_C$  and upto lower critical field.
3. Fig. 1: Type I superconductor below  $T_C$  and below critical field;  
 Fig. 2: Type II superconductor below  $T_C$  upto upper critical field;

## Q6. [June 2025] . 5.0 marks

Solid State Physics &gt; Superconductivity

CSIR NET	2025 June	5M	SSP
----------	-----------	----	-----

The current  $I_J(t)$  through a Josephson junction (shown by the crossed box in the figure) and the voltage  $V(t)$  across it, are given by

$$I_J(t) = I_C \sin \phi(t)$$

$$\frac{d\phi(t)}{dt} = \frac{2eV(t)}{\hbar}$$

where  $I_C$  is the critical current of the junction and  $\phi(t)$  is the phase difference across the junction. A resistor  $R$  is connected in parallel to the junction and a constant current  $I > I_C$  flows through the combination as shown.

The energy dissipated in  $R$  in the time  $\phi$  changes by  $2\pi$  is

1.  $\frac{\hbar}{2e} I$
2.  $\frac{\hbar}{2e} I_C$
3.  $\frac{\hbar}{2e} (I - I_C)$
4.  $\frac{\hbar}{2e} (I + I_C)$

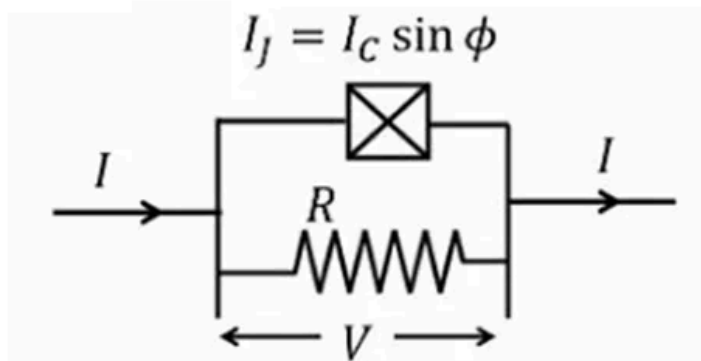

## Answer Key

6 questions . Subject and topic for quick revision

Q. No	Subject	Topic	Answer
Q1	Solid State Physics	Superconductivity	2
Q2	Solid State Physics	Superconductivity	1
Q3	Solid State Physics	Superconductivity	4
Q4	Solid State Physics	Superconductivity	4
Q5	Solid State Physics	Superconductivity	3
Q6	Solid State Physics	Superconductivity	1

## Study with PhysicsByAaryan

---

Full CSIR NET / GATE / JEST / BARC Physics live batch by Aaryan Mehra Sir.  
Concept-first teaching, complete PYQ coverage, daily doubt support.

**Use coupon CONSISTENCY for Rs. 500 off**

### Visit

[www.physicsbyaaryan.com](http://www.physicsbyaaryan.com)

[www.csirnetphysics.com](http://www.csirnetphysics.com)

### Contact

9501976811