

PhysicsByAaryan

CSIR NET . GATE . JEST . BARC - Physics

AD/DA Conversion - CSIR NET Physics PYQs

Electronics . All PYQs (2015-2025) with answer key

4 questions . Answer key included

www.physicsbyaaryan.com . www.csirnetphysics.com

Contact: 9501976811

Q1. [Dec 2017] . 3.5 marks

Electronics > AD/DA Conversion

CSIR NET	2017 Dec	3.5M
----------	----------	------

The full scale voltage of an n -bit Digital-to-Analog Converter is V . The resolution that can be achieved in it is

1. $\frac{V}{(2^n - 1)}$
2. $\frac{V}{(2^n + 1)}$
3. $\frac{V}{2^{2n}}$
4. $\frac{V}{n}$

Q2. [June 2018] . 5.0 marks

Electronics > AD/DA Conversion

CSIR NET	2018 June	5M
----------	-----------	----

The full scale of a 3 -bit digital-to-analog (DAC) converter is $7V$. Which of the following tables represents the output voltage of this 3 -bit DAC for the given set of input bits?

1.

Input bits	Output voltage
000	0
001	1
010	2
011	3

2.

Input bits	Output voltage
000	0
001	1.25
010	2.5
011	3.75

3.

Input bits	Output voltage
000	1.25
001	2.5
010	3.75
011	5

4.

Input bits	Output voltage
000	1
001	2
010	3
011	4

Q3. [Dec 2019] . 3.5 marks

Electronics > AD/DA Conversion

CSIR NET	2019 Dec	3.5M
----------	----------	------

The figure below shows a 2-bit simultaneous analog-to-digital (A/D) converter operating in the voltage range 0 to V_0 . The output of the comparators are C_1 , C_2 and C_3 with the reference inputs $V_0/4$, $V_0/2$ and $3V_0/4$, respectively. The logic expression for the output corresponding to the less significant bit is

1. $C_1 C_2 C_3$
2. $C_2 \bar{C}_3 + \bar{C}_1$
3. $C_1 \bar{C}_2 + C_3$
4. $C_2 \bar{C}_3 + C_2$

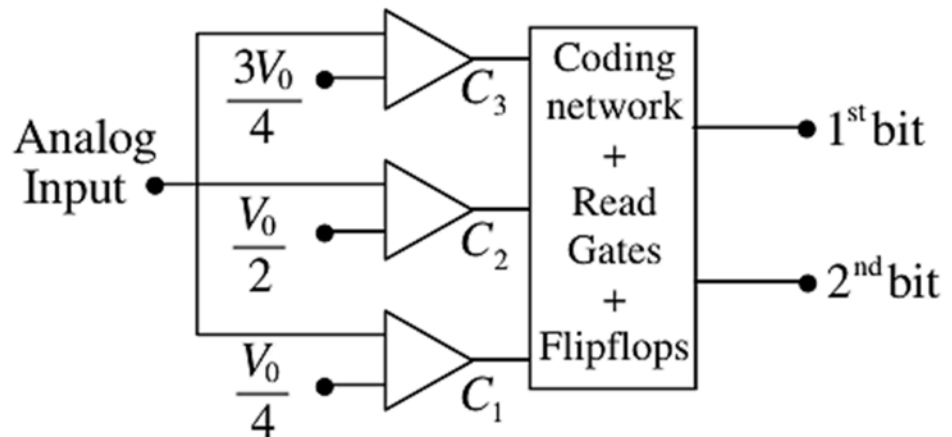

Q4. [June 2024] . 5.0 marks

Electronics > AD/DA Conversion

CSIR NET	2024 June	5M
----------	-----------	----

A piezoresistive pressure sensor utilizes change in electrical resistance (ΔR) with change in pressure (ΔP) as $\Delta R = -R_0 \log_{10} \left(\frac{\Delta P}{P_0} \right)$, where $R_0 = 500\Omega$ and $P_0 = 1000\text{mbar}$. A current of $2\mu\text{A}$ is passed through the sensor and the resultant voltage drop is measured using an analog-to-digital (ADC) converter having a range 0 to 1 V . If a pressure change of 1 mbar is to be measured, amongst the given options, the minimum number of bits needed for the ADC is

1. 12
2. 14
3. 8
4. 10

Answer Key

4 questions . Subject and topic for quick revision

Q. No	Subject	Topic	Answer
Q1	Electronics	AD/DA Conversion	1
Q2	Electronics	AD/DA Conversion	1
Q3	Electronics	AD/DA Conversion	3
Q4	Electronics	AD/DA Conversion	4

Study with PhysicsByAaryan

Full CSIR NET / GATE / JEST / BARC Physics live batch by Aaryan Mehra Sir.
Concept-first teaching, complete PYQ coverage, daily doubt support.

Use coupon CONSISTENCY for Rs. 500 off

Visit

www.physicsbyaaryan.com

www.csirnetphysics.com

Contact

9501976811