

PhysicsByAaryan

CSIR NET . GATE . JEST . BARC - Physics

CSIR NET Physics - Classical Mechanics

All PYQs (2015-2025) with answer key

145 questions . Answer key included

www.physicsbyaaryan.com . www.csirnetphysics.com

Contact: 9501976811

Q1. [Dec 2015] . 3.5 marks

Classical Mechanics > Central forces

CSIR NET	2015 Dec	3.5 M
----------	----------	-------

A particle moves in three dimensional space in a central potential $V(r) = kr^4$ where k is a constant. The angular frequency ω for a circular orbit depends on its radius R as

1. $\omega \propto R$
2. $\omega \propto R^{-1}$
3. $\omega \propto R^{1/4}$
4. $\omega \propto R^{-2/3}$

Q2. [Dec 2015] . 3.5 marks

Classical Mechanics > Rotation Motion

CSIR NET	2015 Dec	3.5 M
----------	----------	-------

Two masses m each, are placed at the points $(x, y) = (a, a)$ and $(-a, -a)$ and two masses, $2m$ each, are placed at the points $(a, -a)$ and $(-a, a)$. The principal moments of inertia of the system are

1. $2m^2, 4ma^2$
2. $4ma^2, 8ma^2$
3. $4ma^2, 4ma^2$
4. $8ma^2, 8ma^2$

Q3. [Dec 2015] . 3.5 marks

Classical Mechanics > Oscillations

CSIR NET	2015 Dec	3.5 M
----------	----------	-------

The Lagrangian of a system is given by

$$L = \frac{1}{2}m\dot{q}_1^2 + 2m\dot{q}_2^2 - k\left(\frac{5}{4}q_1^2 + 2q_2^2 - 2q_1q_2\right)$$

where m and k are positive constants. The frequencies of its normal modes are

1. $\sqrt{\frac{k}{2m}}, \sqrt{\frac{3k}{m}}$
2. $\sqrt{\frac{k}{2m}}(13 \pm \sqrt{73})$
3. $\sqrt{\frac{5k}{2m}}, \sqrt{\frac{k}{m}}$
4. $\sqrt{\frac{k}{2m}}, \sqrt{\frac{6k}{m}}$

Q4. [Dec 2015] . 3.5 marks

Classical Mechanics > Special theory of relativity

CSIR NET	2015 Dec	3.5 M
----------	----------	-------

Consider a particle of mass m moving with a speed v . If T_R denotes the relativistic kinetic energy and T_N its non-relativistic approximation, then the value

of $\frac{(T_R - T_N)}{T_R}$ for $v = 0.01c$, is

1. 1.25×10^{-5}
2. 5.0×10^{-5}
3. 7.5×10^{-5}
4. 1.0×10^{-4}

Q5. [Dec 2015] . 5.0 marks

Classical Mechanics > Oscillations

CSIR NET	2015 Dec	5 M
----------	----------	-----

For a dynamical system governed by the equation

$$\frac{dx}{dt} = 2\sqrt{1 - x^2}, \text{ with } |x| \leq 1$$

1. $x = -1$ and $x = 1$ are both unstable fixed points
2. $x = -1$ and $x = 1$ are both stable fixed points
3. $x = -1$ is an unstable fixed point and $x = 1$ is a stable fixed points
4. $x = -1$ is a stable fixed point and $x = 1$ is a unstable fixed points

Q6. [Dec 2015] . 5.0 marks

Classical Mechanics > Canonical transformations

CSIR NET	2015 Dec	5 M
----------	----------	-----

A canonical transformation $(p, q) \rightarrow (P, Q)$ is performed on the Hamiltonian

$$H = \frac{1}{2mp^2} + \frac{1}{2}m\omega^2q^2$$

via the generating function

$F = \frac{1}{2}m\omega q^2 \cot Q$. If $Q(0) = 0$, which of the following graphs shows schematically the dependence of $Q(t)$ on t ?

1.



2.

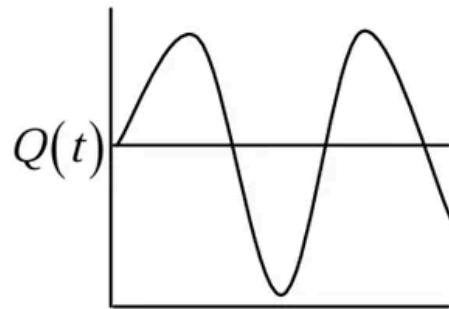

3.

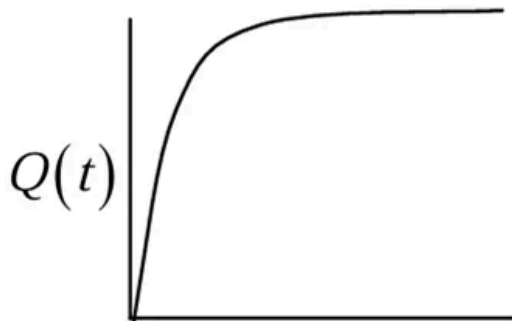

4.

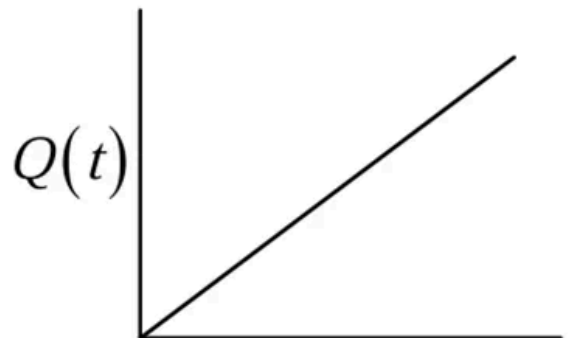

Q7. [Dec 2015] . 5.0 marks

Classical Mechanics > Special theory of relativity

CSIR NET	2015 Dec	5 M
----------	----------	-----

A distant source, emitting radiation of frequency ω moves with a velocity $\frac{4c}{5}$ in a certain direction with respect to a receiver (as shown in the figure). The upper cut-off frequency of the receiver is $\frac{3\omega}{2}$. Let θ the angle as shown. For the receiver to detect the radiation, θ should at least be

Receiver

1. $\cos^{-1} \left(\frac{1}{2} \right)$
2. $\cos^{-1} \left(\frac{3}{4} \right)$
3. $\cos^{-1} \left(\frac{2}{\sqrt{5}} \right)$
4. $\cos^{-1} \left(\sqrt{\frac{2}{3}} \right)$

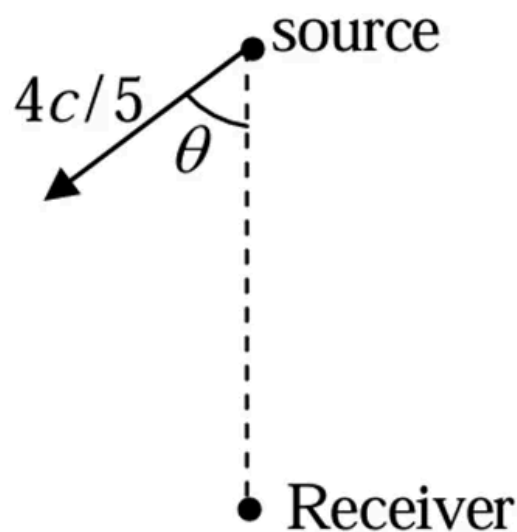

Q8. [Dec 2015] . 5.0 marks

Classical Mechanics > Lagrangian and Hamiltonian

CSIR NET	2015 Dec	5 M
----------	----------	-----

The Lagrangian of a particle moving in a plane is given in Cartesian coordinates as

$$L = \dot{x}\dot{y} - x^2 - y^2$$

In polar coordinates the expression for the canonical momentum p_r (conjugate to the radial coordinate r) is

1. $\dot{r}\sin\theta + r\dot{\theta}\cos\theta$
2. $\dot{r}\cos\theta + r\dot{\theta}\sin\theta$
3. $2\dot{r}\cos\theta - r\dot{\theta}\sin 2\theta$
4. $\dot{r}\sin 2\theta + r\dot{\theta}\cos 2\theta$

Q9. [June 2015] . 3.5 marks

Classical Mechanics > Lagrangian and Hamiltonian

CSIR NET	2015 June	3.5 M
----------	-----------	-------

If the Lagrangian of a dynamical system in two dimensions is $L = \frac{1}{2} m \dot{x}^2 + m \dot{x} \dot{y}$, then its Hamiltonian is

1. $H = \frac{1}{m} p_x p_y + \frac{1}{2m} p_y^2$
2. $H = \frac{1}{m} p_x p_y + \frac{1}{2m} p_x^2$
3. $H = \frac{1}{m} p_x p_y - \frac{1}{2m} p_y^2$
4. $H = \frac{1}{m} p_x p_y - \frac{1}{2m} p_x^2$

Q10. [June 2015] . 3.5 marks

Classical Mechanics > Oscillations

CSIR NET	2015 June	3.5 M
----------	-----------	-------

A particle of mass m moves in the one-dimensional potential $V(x) = \frac{\alpha}{3}x^3 + \frac{\beta}{4}x^4$ where $\alpha, \beta > 0$. One of the equilibrium points is $x = 0$. The angular frequency of small oscillations about the other equilibrium point is

1. $\frac{2\alpha}{\sqrt{3m\beta}}$
2. $\frac{\alpha}{\sqrt{m\beta}}$
3. $\frac{\alpha}{\sqrt{12m\beta}}$
4. $\frac{\alpha}{\sqrt{24m\beta}}$

Q11. [June 2015] . 3.5 marks

Classical Mechanics > Central forces

CSIR NET	2015 June	3.5 M
----------	-----------	-------

A particle of unit mass moves in the xy plane in such a way that $\dot{x}(t) = y(t)$ and $\dot{y}(t) = -x(t)$. We can conclude that it is in a conservative force-field which can be derived from the potential

1. $\frac{1}{2}(x^2 + y^2)$
2. $\frac{1}{2}(x^2 - y^2)$
3. $x + y$
4. $x - y$

Q12. [June 2015] . 3.5 marks

Classical Mechanics > Special theory of relativity

CSIR NET	2015 June	3.5 M
----------	-----------	-------

Consider three inertial frames of reference A , B and C . The frame B moves with a velocity $c/2$ with respect to A , and C moves with a velocity $c/10$ with respect to B in the same direction. The velocity of C as measured in A is

1. $\frac{3c}{7}$
2. $\frac{4c}{7}$
3. $\frac{c}{7}$
4. $\frac{\sqrt{3}c}{7}$

Q13. [June 2015] . 5.0 marks

Classical Mechanics > Canonical transformations

CSIR NET	2015 June	5 M
----------	-----------	-----

Let q and p be the canonical coordinate and momentum of a dynamical system. Which of the following transformations is canonical?

A: $Q_1 = \frac{1}{\sqrt{2}} q^2$ and $P_1 = \frac{1}{\sqrt{2}} p^2$

B: $Q_2 = \frac{1}{\sqrt{2}} (p + q)$ and $P_2 = \frac{1}{\sqrt{2}} (p - q)$

1. neither A nor B
2. both A and B
3. only A
4. only B

Q14. [June 2015] . 5.0 marks

Classical Mechanics > Phase space diagrams

CSIR NET	2015 June	5 M
----------	-----------	-----

Which of the following figures is a schematic representation of the phase space trajectories (i.e., contours of constant energy) of a particle moving in a one-dimensional potential

$$V(x) = -\frac{1}{2}x^2 + \frac{1}{4}x^4?$$

1. 

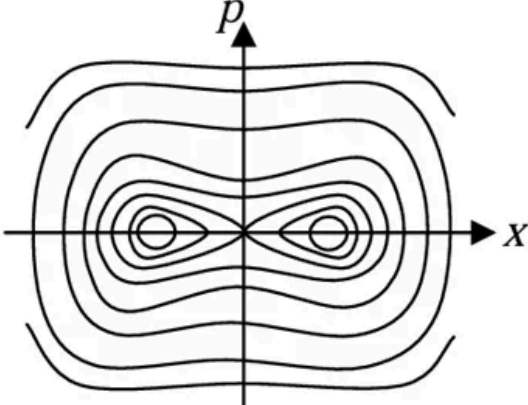

2. 

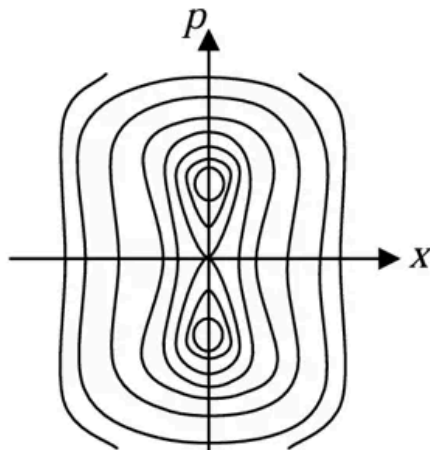

3. 

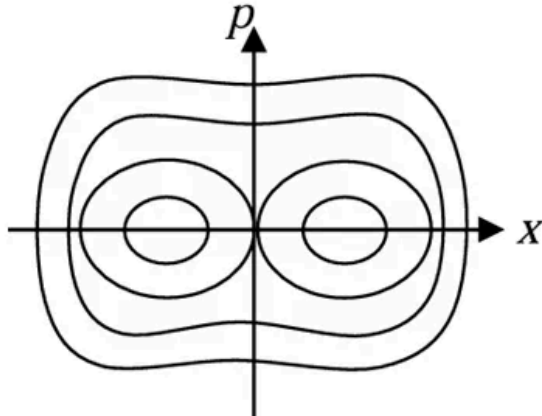

4. 

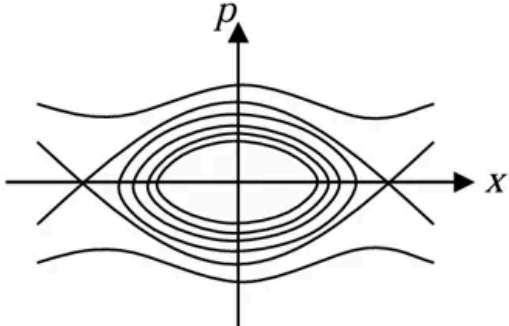

Q15. [June 2015] . 5.0 marks

Classical Mechanics > Special theory of relativity

CSIR NET	2015 June	5 M
----------	-----------	-----

A rod of length L carries a total charge Q distributed uniformly. If this is observed in a frame moving with a speed v along the rod, the charge per unit length (as measured by the moving observer) is

1. $\frac{Q}{L} \left(1 - \frac{v^2}{c^2}\right)$

2. $\frac{Q}{L} \sqrt{1 - \frac{v^2}{c^2}}$

3. $\frac{Q}{L \sqrt{1 - \frac{v^2}{c^2}}}$

4. $\frac{Q}{L \left(1 - \frac{v^2}{c^2}\right)}$

Q16. [Dec 2016] . 3.5 marks

Classical Mechanics > Basic Mechanics

CSIR NET	2016 Dec	3.5M
----------	----------	------

A ball of mass m is dropped from a tall building with zero initial velocity. In addition to gravity, the ball experiences a damping force of the form $-\gamma v$, where v is its instantaneous velocity and γ is a constant. Given the values $m = 10 \text{ kg}$, $\gamma = 10 \text{ kg/s}$, and $g \approx 10 \text{ m/s}^2$, the distance travelled (in metres) in time t in seconds, is

1. $10(t + 1 - e^{-t})$
2. $10(t - 1 + e^{-t})$
3. $5t^2 - (1 - e^t)$
4. $5t^2$

Q17. [Dec 2016] . 3.5 marks

Classical Mechanics > Special theory of relativity

CSIR NET	2016 Dec	3.5M
----------	----------	------

A relativistic particle moves with a constant velocity v with respect to the laboratory frame. In time τ , measured in the rest frame of the particle, the distance that it travels in the laboratory frame is

1. $v\tau$

2. $\frac{c\tau}{\sqrt{1-\frac{v^2}{c^2}}}$

3. $v\tau\sqrt{1-\frac{v^2}{c^2}}$

4. $\frac{v\tau}{\sqrt{1-\frac{v^2}{c^2}}}$

Q18. [Dec 2016] . 3.5 marks

Classical Mechanics > Poisson brackets

CSIR NET	2016 Dec	3.5M
----------	----------	------

A particle in two dimensions is in a potential $V(x, y) = x + 2y$. Which of the following (apart from the total energy of the particle) is also a constant of motion?

1. $p_y - 2p_x$
2. $p_x - 2p_y$
3. $p_x + 2p_y$
4. $p_y + 2p_x$

Q19. [Dec 2016] . 3.5 marks

Classical Mechanics > Lagrangian and Hamiltonian

CSIR NET	2016 Dec	3.5M
----------	----------	------

The dynamics of a particle governed by the Lagrangian $L = \frac{1}{2}m\dot{x}^2 - \frac{1}{2}kx^2 - kx\dot{x}t$ describes

1. an undamped simple harmonic oscillator
2. a damped harmonic oscillator with a time varying damping factor
3. an undamped harmonic oscillator with a time dependent frequency
4. a free particle

Q20. [Dec 2016] . 3.5 marks

Classical Mechanics > Oscillations

CSIR NET	2016 Dec	3.5M
----------	----------	------

The parabolic coordinates (ξ, η) are related to the Cartesian coordinates (x, y) by $x = \xi\eta$ and $y = \frac{1}{2}(\xi^2 - \eta^2)$. The Lagrangian of a two-dimensional simple harmonic oscillator of mass m and angular frequency ω is

1. $\frac{1}{2} m [\dot{\xi}^2 + \dot{\eta}^2 - \omega^2(\xi^2 + \eta^2)]$
2. $\frac{1}{2} m(\xi^2 + \eta^2) \left[(\dot{\xi}^2 + \dot{\eta}^2) - \frac{1}{4} \omega^2(\xi^2 + \eta^2) \right]$
3. $\frac{1}{2} m(\xi^2 + \eta^2) \left(\dot{\xi}^2 + \dot{\eta}^2 - \frac{1}{2} \omega^2 \xi \eta \right)$
4. $\frac{1}{2} m(\xi^2 + \eta^2) \left(\dot{\xi}^2 + \dot{\eta}^2 - \frac{1}{4} \omega^2 \right)$

Q21. [Dec 2016] . 5.0 marks

Classical Mechanics > Basic Mechanics

CSIR NET	2016 Dec	5M
----------	----------	----

After a perfectly elastic collision of two identical balls, one of which was initially at rest, the velocities of both the balls are nonzero. The angle θ between the final velocities (in the lab frame) is

1. $\theta = \frac{\pi}{2}$

2. $\theta = \pi$

3. $0 < \theta \leq \frac{\pi}{2}$

4. $\frac{\pi}{2} < \theta \leq \pi$

Q22. [Dec 2016] . 5.0 marks

Classical Mechanics > Central forces

CSIR NET	2016 Dec	5M
----------	----------	----

Consider circular orbits in a central force potential

$V(r) = -\frac{k}{r^n}$, where $k > 0$ and $0 < n < 2$. If the time period of a circular orbit of radius R is T_1 and that of radius $2R$ is T_2 , then T_2/T_1 is

1. $2^{\frac{n}{2}}$
2. $2^{\frac{2}{3}n}$
3. $2^{\frac{n}{2}+1}$
4. 2^n

Q23. [Dec 2016] . 5.0 marks

Classical Mechanics > Special theory of relativity

CSIR NET	2016 Dec	5M
----------	----------	----

Consider a radioactive nucleus that is travelling at a speed $c/2$ with respect to the lab frame. It emits γ -rays of frequency ν_0 in its rest frame. There is a stationary detector (which is not on the path of the nucleus) in the lab. If a γ -ray photon is emitted when the nucleus is closest to the detector, its observed frequency at the detector is

1. $\frac{\sqrt{3}}{2} \nu_0$

2. $\frac{1}{\sqrt{3}} \nu_0$

3. $\frac{1}{\sqrt{2}} \nu_0$

4. $\sqrt{\frac{2}{3}} \nu_0$

Q24. [June 2016] . 3.5 marks

Classical Mechanics > Special theory of relativity

CSIR NET	2016 June	3.5M
----------	-----------	------

Let (x, t) and (x', t') be the coordinate systems used by the observers O and O' , respectively. Observer O' moves with a velocity $v = \beta c$ along their common positive x -axis. If $x_+ = x + ct$ and $x_- = x - ct$ are the linear combinations of the coordinates, the Lorentz transformation relating O and O' takes the form

$$1. x'_+ = \frac{x_- - \beta x_+}{\sqrt{1 - \beta^2}} \text{ and } x'_- = \frac{x_+ - \beta x_-}{\sqrt{1 - \beta^2}},$$

$$2. x'_+ = \sqrt{\frac{1 + \beta}{1 - \beta}} x_+ \text{ and } x'_- = \sqrt{\frac{1 - \beta}{1 + \beta}} x_-$$

$$3. x'_+ = \frac{x_+ - \beta x_-}{\sqrt{1 - \beta^2}} \text{ and } x'_- = \frac{x_- - \beta x_+}{\sqrt{1 - \beta^2}},$$

$$4. x'_+ = \sqrt{\frac{1 - \beta}{1 + \beta}} x_+ \text{ and } x'_- = \sqrt{\frac{1 + \beta}{1 - \beta}} x_-$$

Q25. [June 2016] . 3.5 marks

Classical Mechanics > Basic Mechanics

CSIR NET	2016 June	3.5M
----------	-----------	------

A ball of mass m , initially at rest, is dropped from a height of 5 meters. If the coefficient of restitution is 0.9, the speed of the ball just before it hits the floor the second time is approximately (take $g = 9.8 \text{ m/s}^2$)

1. 9.80 m/s
2. 9.10 m/s
3. 8.91 m/s
4. 7.02 m/s

Q26. [June 2016] . 3.5 marks

Classical Mechanics > Lagrangian and Hamiltonian

CSIR NET	2016 June	3.5M
----------	-----------	------

The Hamiltonian of a system with generalized coordinate and momentum (q, p) is $H = p^2 q^2$. A solution of the Hamiltonian equation of motion is (in the following A and B are constants)

$$1. p = B e^{-2At}, q = \frac{A}{B} e^{2At}$$

$$2. p = A e^{-2At}, q = \frac{A}{B} e^{-2At}$$

$$3. p = A e^{At}, q = \frac{A}{B} e^{-At}$$

$$4. p = 2A e^{-A^2 t}, q = \frac{A}{B} e^{A^2 t}$$

Q27. [June 2016] . 5.0 marks

Classical Mechanics > Special theory of relativity

CSIR NET	2016 June	5M
----------	-----------	----

For a particle of energy E and momentum \mathbf{p} (in a frame F), the rapidity y is defined as

$y = \frac{1}{2} \ln \left(\frac{E+p_3c}{E-p_3c} \right)$. In a frame F' moving with velocity $\mathbf{v} = (0,0,\beta c)$ with respect to F , the rapidity y' will be

1. $y' = y + \frac{1}{2} \ln(1 - \beta^2)$

2. $y' = y - \frac{1}{2} \ln \left(\frac{1+\beta}{1-\beta} \right)$

3. $y' = y + \ln \left(\frac{1+\beta}{1-\beta} \right)$

4. $y' = y + 2 \ln \left(\frac{1+\beta}{1-\beta} \right)$

Q28. [June 2016] . 5.0 marks

Classical Mechanics > Canonical transformations

CSIR NET	2016 June	5M
----------	-----------	----

A canonical transformation $(q, p) \rightarrow (Q, P)$ is made through the generating function $F(q, P) = q^2 P$ on the Hamiltonian

$$H(q, p) = \frac{p^2}{2\alpha q^2} + \frac{\beta}{4} q^4$$

where α and β are constants. The equations of motion for (Q, P) are

1. $\dot{Q} = P/\alpha$ and $\dot{P} = -\beta Q$
2. $\dot{Q} = 4P/\alpha$ and $\dot{P} = -\beta Q/2$
3. $\dot{Q} = P/\alpha$ and $\dot{P} = -\frac{2P^2}{Q} - \beta Q$
4. $\dot{Q} = 2P/\alpha$ and $\dot{P} = -\beta Q$

Q29. [June 2016] . 5.0 marks

Classical Mechanics > Lagrangian and Hamiltonian

CSIR NET	2016 June	5M
----------	-----------	----

The Lagrangian of a system moving in three dimensions is

$$L = \frac{1}{2}m\dot{x}_1^2 + m(\dot{x}_2^2 + \dot{x}_3^2) - \frac{1}{2}kx_1^2 - \frac{1}{2}k(x_2 + x_3)^2$$

The independent constant(s) of motion is/are

1. energy alone
2. only energy, one component of the linear momentum and one component of the angular momentum.
3. only energy and one component of the linear momentum
4. only energy and one component of the angular momentum

Q30. [Dec 2017] . 3.5 marks

Classical Mechanics > Pseudo Forces

CSIR NET	2017 Dec	3.5M
----------	----------	------

A disc of mass m is free to rotate in a plane parallel to the xy plane with an angular velocity $-\omega\hat{z}$ about a massless rigid rod suspended from the roof of a stationary car (as shown in the figure below). The rod is free to orient itself along any direction.

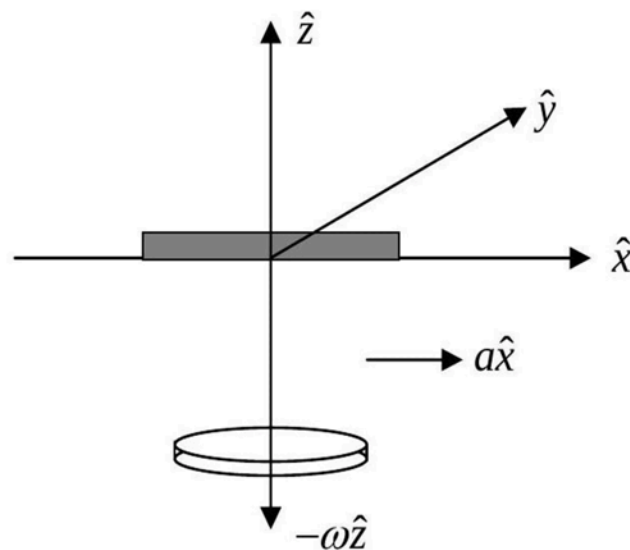

The car accelerates in the positive x -direction with an acceleration $a > 0$. Which of the following statements is true for the coordinates of the centre of mass of the disc in the reference frame of the car?

1. only the x and the z coordinates change
2. only the y and the z coordinates change
3. only the x and the y coordinates change
4. all the three coordinates change

Q31. [Dec 2017] . 3.5 marks

Classical Mechanics > Basic Mechanics

CSIR NET	2017 Dec	3.5M
----------	----------	------

A cyclist, weighing a total of 80 kg with the bicycle, pedals at a speed of 10 m/s. She stops pedalling at an instant which is taken to be $t = 0$. Due to the velocity dependent frictional force, her velocity is

found to vary as $v(t) = \frac{10}{\left(1 + \frac{t}{30}\right)} \text{ m.s}$, where t is

measured in seconds. When the velocity drops to 8 m/s, she starts pedalling again to maintain a constant speed. The energy expended by her in 1 minute at this (new) speed, is

1. 4kJ
2. 8 kJ
3. 16 kJ
4. 32 kJ

Q32. [Dec 2017] . 3.5 marks

Classical Mechanics > Special theory of relativity

CSIR NET	2017 Dec	3.5M
----------	----------	------

A light signal travels from a point A to a point B , both within a glass slab that is moving with uniform velocity (in the same direction as the light) with speed $0.3c$ with respect to an external observer. If the refractive index of the slab is 1.5 , then the observer will measure the speed of the signal as

1. $0.67c$
2. $0.81c$
3. $0.97c$
4. c

Q33. [Dec 2017] . 3.5 marks

Classical Mechanics > Oscillations

CSIR NET	2017 Dec	3.5M
----------	----------	------

A monoatomic gas of volume V is in equilibrium in a uniform vertical cylinder, the lower end of which is closed by a rigid wall and the other by a frictionless piston. The piston is pressed lightly and released. Assume that the gas is a poor conductor of heat and the cylinder and piston are perfectly insulating. If the cross-sectional area of the cylinder is A , the angular frequency of small oscillations of the piston about the point of equilibrium, is

1. $\sqrt{5gA/(3V)}$

2. $\sqrt{4gA/(3V)}$

3. $\frac{5}{3}\sqrt{gA/V}$

4. $\sqrt{7gA/(5V)}$

Q34. [Dec 2017] . 3.5 marks

Classical Mechanics > Oscillations

CSIR NET	2017 Dec	3.5M
----------	----------	------

The spring constant k of a spring of mass m_s , is determined experimentally by loading the spring with mass M and recording the time period T , for a single oscillation. If the experiment is carried out for different masses, then the graph that correctly represents the result is

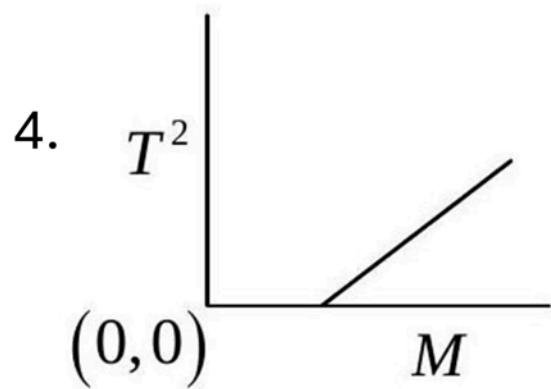
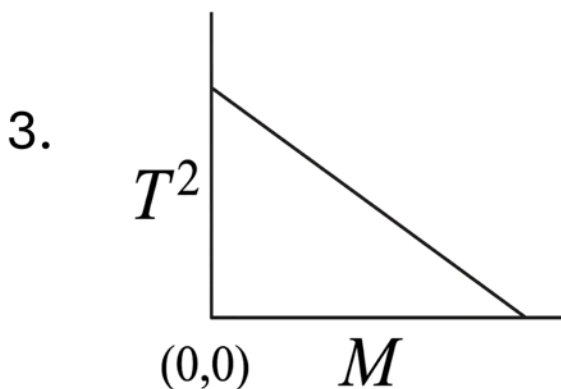
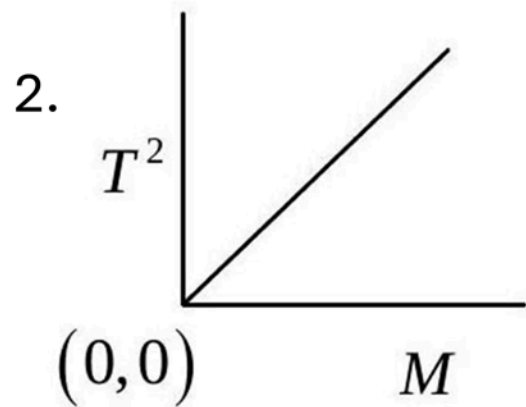
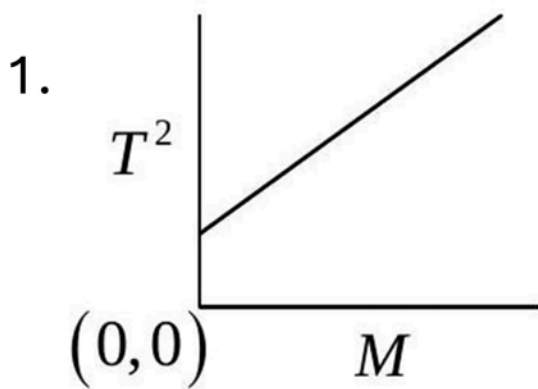

Q35. [Dec 2017] . 5.0 marks

Classical Mechanics > Phase space diagrams

CSIR NET	2017 Dec	5M
----------	----------	----

A particle moves in one dimension in a potential $V(x) = -k^2x^4 + \omega^2x^2$ where k and ω are constants. Which of the following curves best describes the trajectories of this system in phase space?

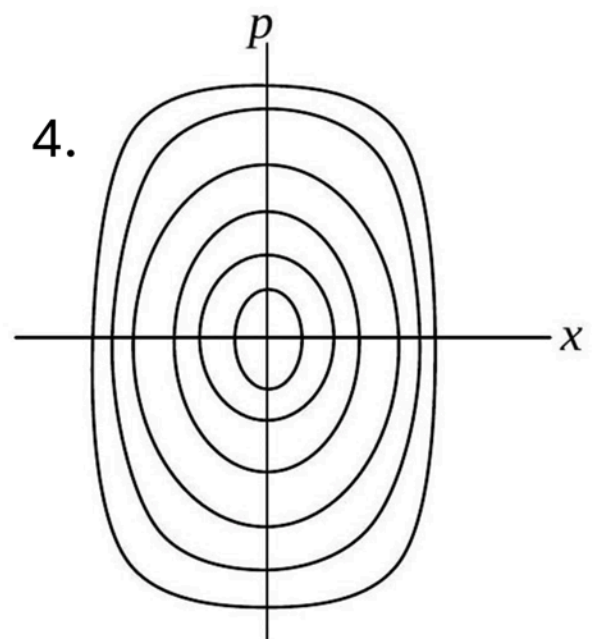
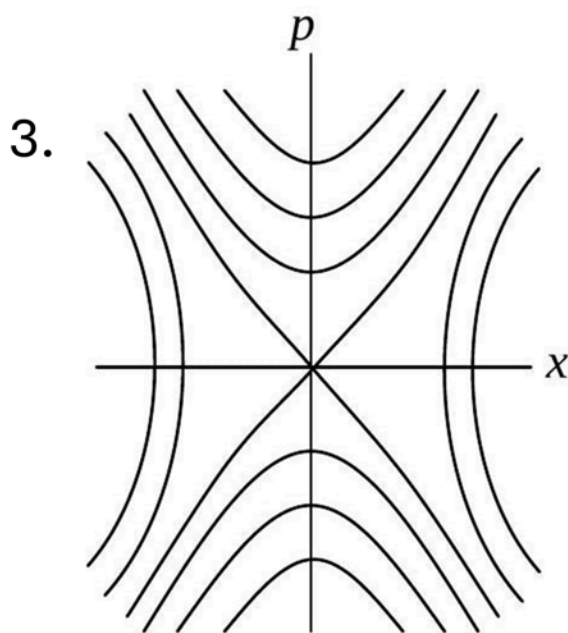
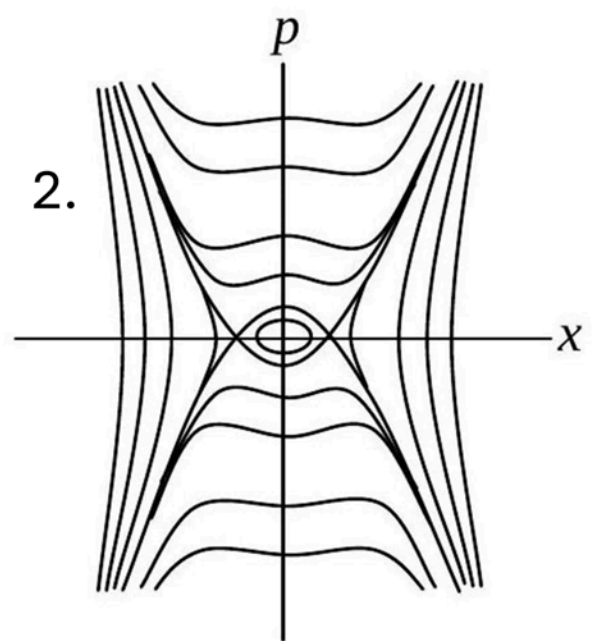
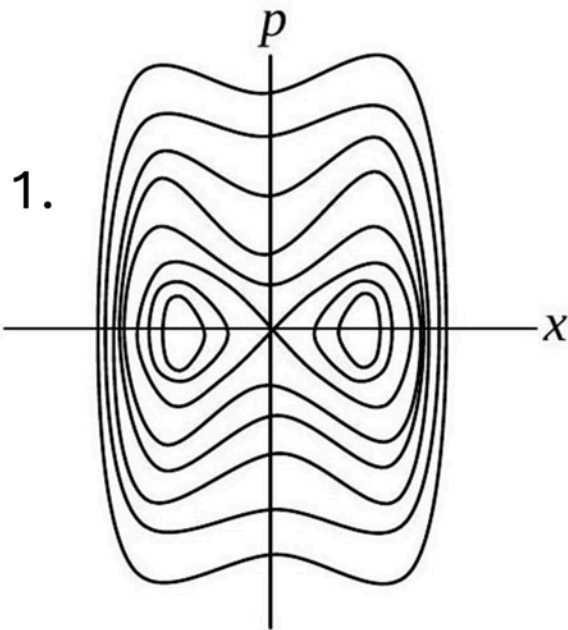

Q36. [Dec 2017] . 5.0 marks

Classical Mechanics > Canonical transformations

CSIR NET	2017 Dec	5M
----------	----------	----

Let (x, p) be the generalized coordinate and momentum of a Hamiltonian system. If new variables (X, P) are defined by $X = x^\alpha \sinh(\beta p)$ and $P = x^\gamma \cosh(\beta p)$, where α, β and γ are constants, then the conditions for it to be a canonical transformation, are

1. $\alpha = \frac{1}{2\beta} (\beta + 1)$ and $\gamma = \frac{1}{2\beta} (\beta - 1)$
2. $\beta = \frac{1}{2\gamma} (\alpha + 1)$ and $\gamma = \frac{1}{2\alpha} (\alpha - 1)$
3. $\alpha = \frac{1}{2\beta} (\beta - 1)$ and $\gamma = \frac{1}{2\beta} (\beta + 1)$
4. $\beta = \frac{1}{2\gamma} (\alpha - 1)$ and $\gamma = \frac{1}{2\alpha} (\alpha + 1)$

Q37. [Dec 2017] . 5.0 marks

Classical Mechanics > Central forces

CSIR NET	2017 Dec	5M
----------	----------	----

Consider a set of particles which interact by a pair potential $V = ar^6$ where r is the interparticle separation and $a > 0$ is a constant. If a system of such particles has reached virial equilibrium, the ratio of the kinetic to the total energy of the system is

1. $\frac{1}{2}$
2. $\frac{1}{3}$
3. $\frac{3}{4}$
4. $\frac{2}{3}$

Q38. [Dec 2017] . 5.0 marks

Classical Mechanics > Special theory of relativity

CSIR NET	2017 Dec	5M
----------	----------	----

In an inertial frame S , the magnetic vector potential in a region of space is given by $\vec{A} = az\hat{i}$ (where a is a constant) and the scalar potential is zero. The electric and magnetic fields seen by an inertial observer moving with a velocity $v\hat{i}$ with respect to

S , are, respectively [In the following $\gamma = \frac{1}{\sqrt{1-\frac{v^2}{c^2}}}$]

1. 0 and $\gamma a\hat{j}$
2. $-va\hat{k}$ and $\gamma a\hat{i}$
3. $v\gamma a\hat{k}$ and $v\gamma a\hat{j}$
4. $v\gamma a\hat{k}$ and $\gamma a\hat{j}$

Q39. [June 2017] . 3.5 marks

Classical Mechanics > Lagrangian and Hamiltonian

CSIR NET	2017 June	3.5M
----------	-----------	------

The Hamiltonian for a system described by the generalised coordinate x and generalised momentum p is

$$H = \alpha x^2 p + \frac{p^2}{2(1 + 2\beta x)} + \frac{1}{2} \omega^2 x^2$$

where α, β and ω are constants. The corresponding Lagrangian is

1. $\frac{1}{2} (\dot{x} - \alpha x^2)^2 (1 + 2\beta x) - \frac{1}{2} \omega^2 x^2$
2. $\frac{1}{2(1+2\beta x)} \dot{x}^2 - \frac{1}{2} \omega^2 x^2 - \alpha x^2 \dot{x}$
3. $\frac{1}{2} (\dot{x}^2 - \alpha^2 x)^2 (1 + 2\beta x) - \frac{1}{2} \omega^2 x^2$
4. $\frac{1}{2(1+2\beta x)} \dot{x}^2 - \frac{1}{2} \omega^2 x^2 + \alpha x^2 \dot{x}$

Q40. [June 2017] . 3.5 marks

Classical Mechanics > Special theory of relativity

CSIR NET	2017 June	3.5M
----------	-----------	------

An inertial observer sees two events E_1 and E_2 happening at the same location but $6\mu\text{ s}$ apart in time. Another observer moving with a constant velocity v (with respect to the first one) sees the same events to be $9\mu\text{ s}$ apart. The spatial distance between the events, as measured by the second observer, is approximately

1. 300 m
2. 1000 m
3. 2000 m
4. 2700 m

Q41. [June 2017] . 3.5 marks

Classical Mechanics > Basic Mechanics

CSIR NET	2017 June	3.5M
----------	-----------	------

A ball weighing 100 gm , released from a height of 5 m , bounces perfectly elastically off a plate. The collision time between the ball and the plate is 0.5s . The average force on the plate is approximately

1. 3 N
2. 2 N
3. 5 N
4. 4 N

Q42. [June 2017] . 3.5 marks

Classical Mechanics > Oscillations

CSIR NET	2017 June	3.5M
----------	-----------	------

A solid vertical rod, of length L and cross-sectional area A , is made of a material of Young's modulus Y . The rod is loaded with a mass M , and, as a result, extends by a small amount ΔL in the equilibrium condition. The mass is then suddenly reduced to $M/2$. As a result, the rod will undergo longitudinal oscillation with an angular frequency

1. $\sqrt{2YA/ML}$
2. $\sqrt{YA/ML}$
3. $\sqrt{2YA/M\Delta L}$
4. $\sqrt{YA/M\Delta L}$

Q43. [June 2017] . 5.0 marks

Classical Mechanics > Lagrangian and Hamiltonian

CSIR NET	2017 June	5M
----------	-----------	----

The Lagrangian of a free relativistic particle (in one dimension) of mass m is given by $L = -m\sqrt{1 - \dot{x}^2}$ where $\dot{x} = dx/dt$. If such a particle is acted upon by a constant force in the direction of its motion, the phase space trajectories obtained from the corresponding Hamiltonian are

1. Ellipses
2. Cycloids
3. Hyperbolas
4. Parabolas

Q44. [June 2017] . 5.0 marks

Classical Mechanics > Canonical transformations

CSIR NET	2017 June	5M
----------	-----------	----

A Hamiltonian system is described by the canonical coordinate q and canonical momentum p . A new coordinate Q is defined as $Q(t) = q(t + \tau) + p(t + \tau)$, where t is the time and τ is a constant, that is, the new coordinate is a combination of the old coordinate and momentum at a shifted time. The new canonical momentum $P(t)$ can be expressed as

1. $p(t + \tau) - q(t + \tau)$
2. $p(t + \tau) - q(t - \tau)$
3. $\frac{1}{2} [p(t - \tau) - q(t + \tau)]$
4. $\frac{1}{2} [p(t + \tau) - q(t + \tau)]$

Q45. [June 2017] . 5.0 marks

Classical Mechanics > Lagrangian and Hamiltonian

CSIR NET	2017 June	5M
----------	-----------	----

The energy of a one-dimensional system, governed by the Lagrangian

$$L = \frac{1}{2} m \dot{x}^2 - \frac{1}{2} k x^{2n}$$

where k and n are two positive constants, is E_0 . The time period of oscillation τ satisfies

1. $\tau \propto k^{-\frac{1}{n}}$
2. $\tau \propto k^{-\frac{1}{2n}} E_0^{\frac{1-n}{2n}}$
3. $\tau \propto k^{-\frac{1}{2n}} E_0^{\frac{n-2}{2n}}$
4. $\tau \propto k^{-\frac{1}{n}} E_0^{\frac{1+n}{2n}}$

Q46. [Dec 2018] . 3.5 marks

Classical Mechanics > Basic Mechanics

CSIR NET	2018 Dec	3.5M
----------	----------	------

A particle of mass m , moving along the x - direction, experiences a damping force $-\gamma v^2$, where γ is a constant and v is its instantaneous speed. If the speed at $t = 0$ is v_0 , the speed at time t is

1. $v_0 e^{-\frac{\gamma v_0 t}{m}}$

2. $\frac{v_0}{1 + \ln\left(1 + \frac{\gamma v_0 t}{m}\right)}$

3. $\frac{m v_0}{m + \gamma v_0 t}$

4. $\frac{2 v_0}{1 + e^{\frac{\gamma v_0 t}{m}}}$

Q47. [Dec 2018] . 3.5 marks

Classical Mechanics > Central forces

CSIR NET	2018 Dec	3.5M
----------	----------	------

In the attractive Kepler problem described by the central potential $V(r) = \frac{-k}{r}$ (where k is a positive constant), a particle of mass m with a non-zero angular momentum can never reach the center due to the centrifugal barrier. If we modify the potential to

$$V(r) = -\frac{k}{r} - \frac{\beta}{r^3}$$

one finds that there is a critical value of the angular momentum ℓ_c below which there is no centrifugal barrier. This value of ℓ_c is

1. $[12km^2\beta]^{1/2}$
2. $[12 km^2\beta]^{-1/2}$
3. $[12 km^2\beta]^{1/4}$
4. $[12km^2\beta]^{-1/4}$

Q48. [Dec 2018] . 3.5 marks

Classical Mechanics > Oscillations

CSIR NET	2018 Dec	3.5M
----------	----------	------

The time period of a particle of mass m , undergoing small oscillations around $x = 0$, in the potential

$$V = V_0 \cosh\left(\frac{x}{L}\right), \text{ is}$$

1. $\pi \sqrt{\frac{mL^2}{V_0}}$

2. $2\pi \sqrt{\frac{mL^2}{2V_0}}$

3. $2\pi \sqrt{\frac{mL^2}{V_0}}$

4. $2\pi \sqrt{\frac{2mL^2}{V_0}}$

Q49. [Dec 2018] . 3.5 marks

Classical Mechanics > Special theory of relativity

CSIR NET	2018 Dec	3.5M
----------	----------	------

Consider the decay $A \rightarrow B + C$ of a relativistic spin- $\frac{1}{2}$ particle A . Which of the following statements is true in the rest frame of the particle A ?

1. The spin of both B and C may be $\frac{1}{2}$
2. The sum of the masses of B and C is greater than the mass of A
3. The energy of B is uniquely determined by the masses of the particles
4. The spin of both B and C may be integral

Q50. [Dec 2018] . 5.0 marks

Classical Mechanics > Lagrangian and Hamiltonian

CSIR NET

2018 Dec

5M

The motion of a particle in one dimension is described

by the Lagrangian $L = \frac{1}{2} \left(\left(\frac{dx}{dt} \right)^2 - x^2 \right)$ in suitable units.

The value of the action along the classical path from $x = 0$ at $t = 0$ to $x = x_0$ at $t = t_0$, is

1. $\frac{x_0^2}{2\sin^2 t_0}$
2. $\frac{1}{2} x_0^2 \tan t_0$
3. $\frac{1}{2} x_0^2 \cot t_0$
4. $\frac{x_0^2}{2\cos^2 t_0}$

Q51. [Dec 2018] . 5.0 marks

Classical Mechanics > Lagrangian and Hamiltonian

CSIR NET	2018 Dec	5M
----------	----------	----

The Hamiltonian of a classical one-dimensional harmonic oscillator is $H = \frac{1}{2}(p^2 + x^2)$, in suitable units. The total time derivative of the dynamical variable $(p + \sqrt{2}x)$ is

1. $\sqrt{2}p - x$
2. $p - \sqrt{2}x$
3. $p + \sqrt{2}x$
4. $x + \sqrt{2}p$

Q52. [Dec 2018] . 5.0 marks

Classical Mechanics > Special theory of relativity

CSIR NET	2018 Dec	5M
----------	----------	----

A relativistic particle of mass m and charge e is moving in a uniform electric field of strength ε . Starting from rest at $t = 0$, how much time will it take to reach the speed $\frac{c}{2}$?

1. $\frac{1}{\sqrt{3}} \frac{mc}{e\varepsilon}$

2. $\frac{mc}{e\varepsilon}$

3. $\sqrt{2} \frac{mc}{e\varepsilon}$

4. $\sqrt{\frac{3}{2}} \frac{mc}{e\varepsilon}$

Q53. [June 2018] . 3.5 marks

Classical Mechanics > Oscillations

CSIR NET	2018 June	3.5M
----------	-----------	------

A particle moves in the one-dimensional potential $V(x) = \alpha x^6$, where $a > 0$ is a constant. If the total energy of the particle is E , its time period in a periodic motion is proportional to

1. $E^{-1/3}$
2. $E^{-1/2}$
3. $E^{1/3}$
4. $E^{1/2}$

Q54. [June 2018] . 3.5 marks

Classical Mechanics > Central forces

CSIR NET	2018 June	3.5M
----------	-----------	------

Which of the following figures best describes the trajectory of a particle moving in a repulsive central potential $V(r) = \frac{a}{r}$ ($a > 0$ is a constant)?

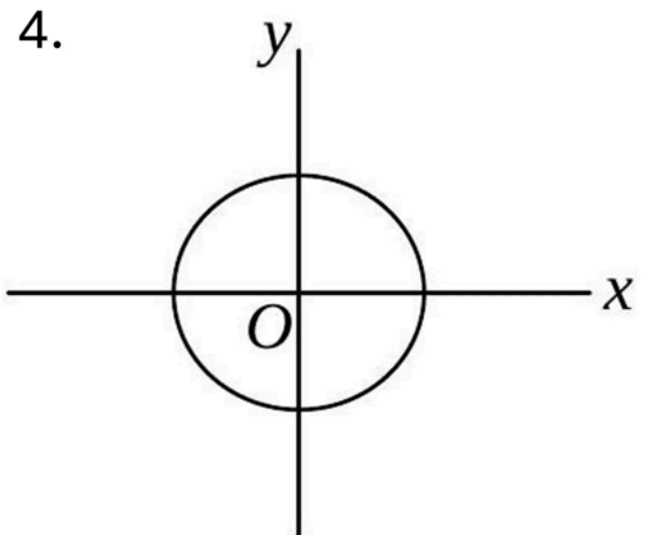
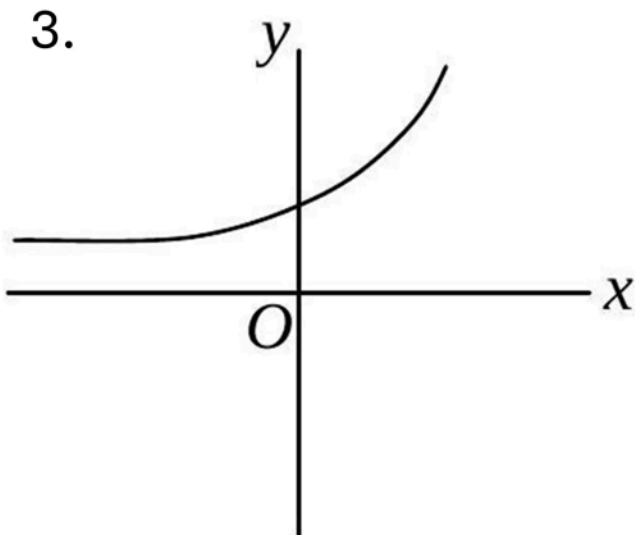
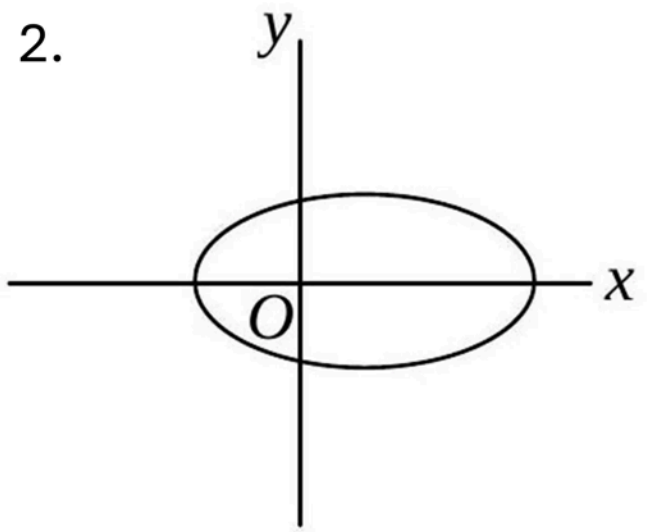
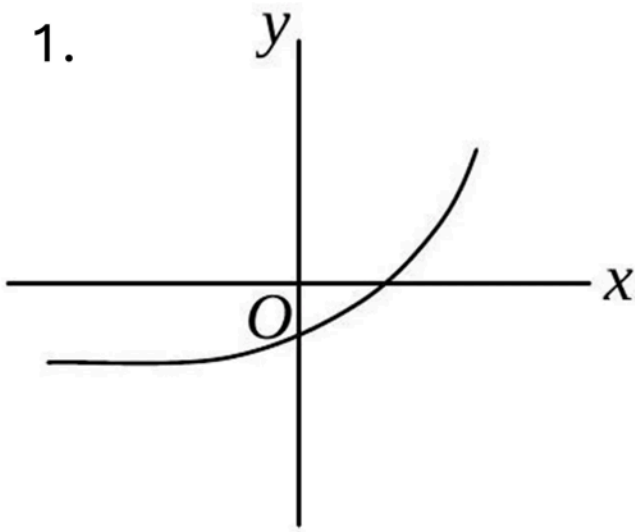

Q55. [June 2018] . 3.5 marks

Classical Mechanics > Special theory of relativity

CSIR NET	2018 June	3.5M
----------	-----------	------

Two particles A and B move with relativistic velocities of equal magnitude v , but in opposite directions, along the x -axis of an inertial frame of reference. The magnitude of the velocity of A , as seen from the rest frame of B , is

1. $\frac{2v}{\left(1 - \frac{v^2}{c^2}\right)}$

2. $\frac{2v}{\left(1 + \frac{v^2}{c^2}\right)}$

3. $2v \sqrt{\frac{c-v}{c+v}}$

4. $\frac{2v}{\sqrt{1 - \frac{v^2}{c^2}}}$

Q56. [June 2018] . 3.5 marks

Classical Mechanics > Oscillations

CSIR NET	2018 June	3.5M
----------	-----------	------

A particle of mass m , kept in potential $V(x) = -\frac{1}{2}kx^2 + \frac{1}{4}\lambda x^4$ (where k and λ are positive constants), undergoes small oscillations about an equilibrium point. The frequency of oscillations is

1. $\frac{1}{2\pi} \sqrt{\frac{2\lambda}{m}}$

2. $\frac{1}{2\pi} \sqrt{\frac{k}{m}}$

3. $\frac{1}{2\pi} \sqrt{\frac{2k}{m}}$

4. $\frac{1}{2\pi} \sqrt{\frac{\lambda}{m}}$

Q57. [June 2018] . 5.0 marks

Classical Mechanics > Central forces

CSIR NET	2018 June	5M
----------	-----------	----

A particle of mass m moves in a central potential

$V(r) = -\frac{k}{r}$ in an elliptic orbit $r(\theta) = \frac{a(1-e^2)}{1+e\cos\theta}$, where

$0 \leq \theta < 2\pi$ and a and e denote the semi-major axis and eccentricity, respectively. If its total energy is

$E = -\frac{k}{2a}$, the maximum kinetic energy is

1. $E(1 - e^2)$
2. $E \frac{(e+1)}{(e-1)}$
3. $E/(1 - e^2)$
4. $E \frac{(e-1)}{(e+1)}$

Q58. [June 2018] . 5.0 marks

Classical Mechanics > Lagrangian and Hamiltonian

CSIR NET	2018 June	5M
----------	-----------	----

The Hamiltonian of a one-dimensional system is

$$H = \frac{xp^2}{2m} + \frac{1}{2}kx, \text{ where } m \text{ and } k \text{ are positive}$$

constants. The corresponding Euler-Lagrange equation for the system is

1. $m\ddot{x} + k = 0$

2. $m\ddot{x} + 2\dot{x} + kx^2 = 0$

3. $2mx\ddot{x} - m\dot{x}^2 + kx^2 = 0$

4. $mx\ddot{x} + 2m\dot{x}^2 + kx^2 = 0$

Q59. [June 2018] . 5.0 marks

Classical Mechanics > Special theory of relativity

CSIR NET	2018 June	5M
----------	-----------	----

An inertial frame K' moves with a constant speed v with respect to another inertial frame K along their common x -direction. Let (x, ct) and (x', ct') denote the spacetime coordinates in the frames K and K' , respectively. Which of the following spacetime diagrams correctly describes the t' - axis ($x' = 0$ line) and the x' - axis ($t' = 0$ line) in the x - ct plane? (In the following figures $\tan \phi = v/c$)

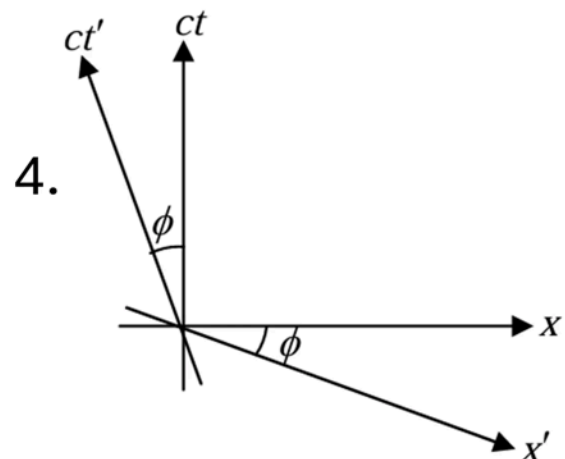
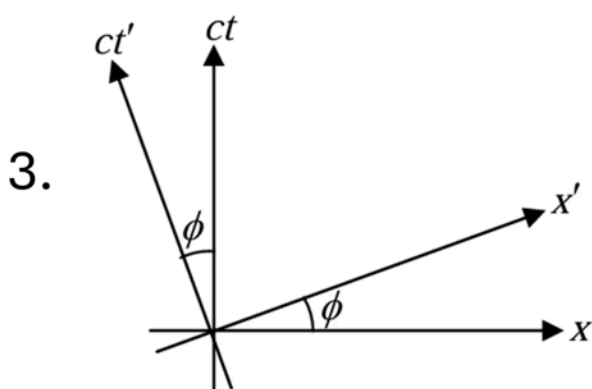
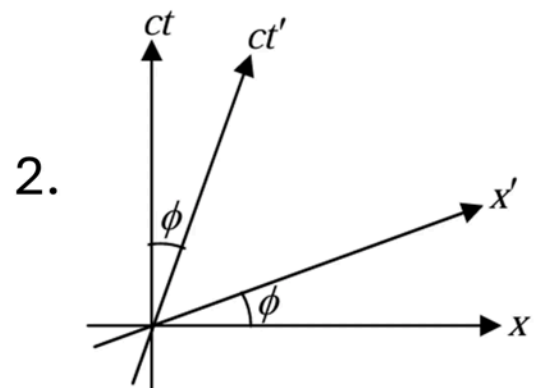
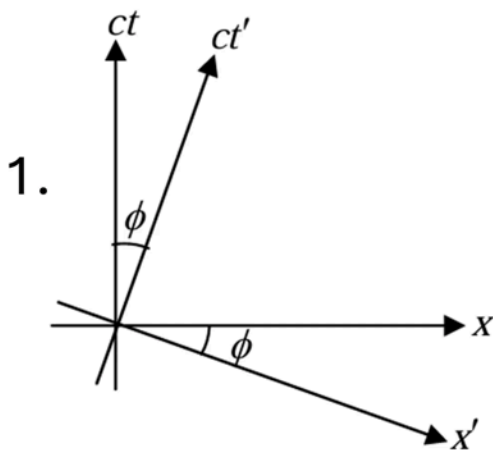

Q60. [June 2018] . 5.0 marks

Classical Mechanics > Special theory of relativity

CSIR NET	2018 June	5M
----------	-----------	----

The energy of a free relativistic particle is $E = \sqrt{|\vec{p}|^2 c^2 + m^2 c^4}$, where m is its rest mass, \vec{p} is its momentum and c is the speed of light in vacuum. The ratio v_g/v_p of the group velocity v_g of a quantum mechanical wave packet (describing this particle) to the phase velocity v_p is

1. $|\vec{p}|c/E$
2. $|\vec{p}|mc^3/E^2$
3. $|\vec{p}|^2 c^3/E^2$
4. $|\vec{p}|c/2E$

Q61. [Dec 2019] . 3.5 marks

Classical Mechanics > Basic Mechanics

CSIR NET	2019 Dec	3.5M
----------	----------	------

A ball, initially at rest, is dropped from a height h above the floor bounces again and again vertically. If the coefficient of restitution between the ball and the floor is 0.5, the total distance travelled by the ball before it comes to rest is

1. $\frac{8h}{3}$
2. $\frac{5h}{3}$
3. $3h$
4. $2h$

Q62. [Dec 2019] . 3.5 marks

Classical Mechanics > Phase space diagrams

CSIR NET	2019 Dec	3.5M
----------	----------	------

A block of mass m , attached to a spring, oscillates horizontally on a surface. The coefficient of friction between the block and the surface is μ .

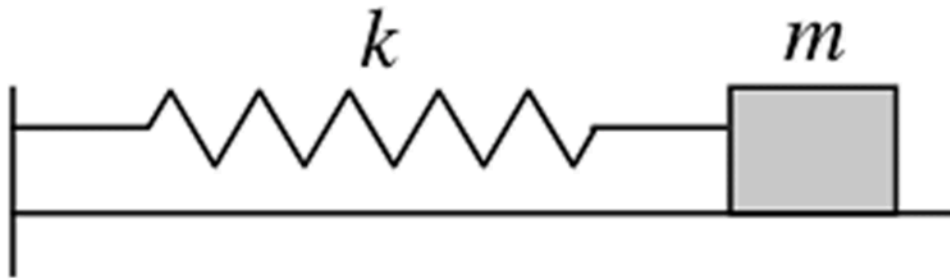

Which of the following trajectories best describes the motion of the block in the phase space (xp_x -plane)?

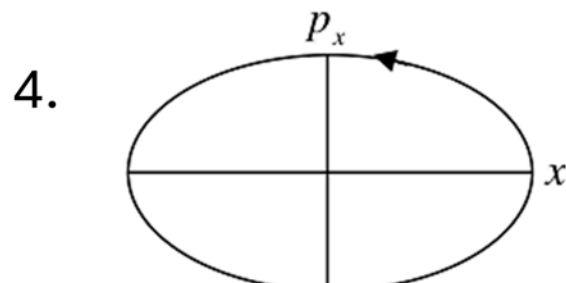
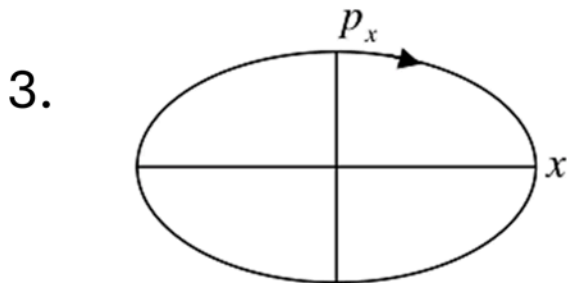
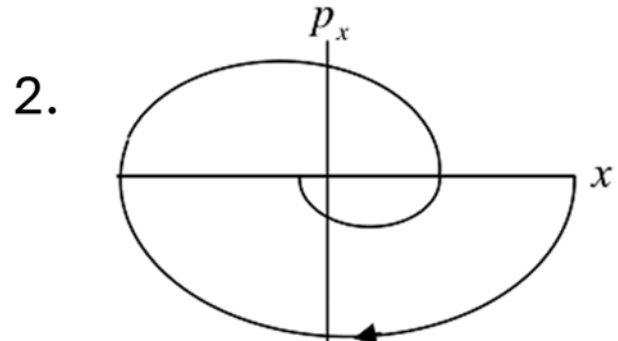
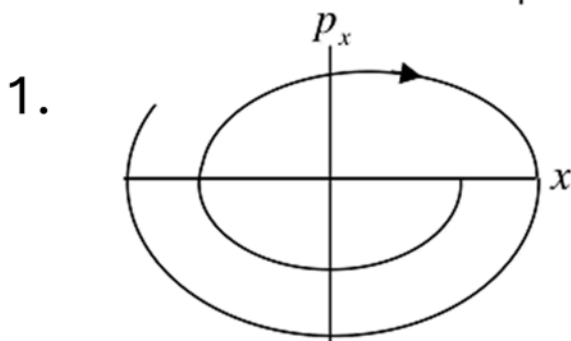

Q63. [Dec 2019] . 3.5 marks

Classical Mechanics > Lagrangian and Hamiltonian

CSIR NET	2019 Dec	3.5M
----------	----------	------

Which of the following terms, when added to the Lagrangian $L(x, y, \dot{x}, \dot{y})$ of a system with two degrees of freedom will not change the equations of motion?

1. $x\ddot{x} - y\ddot{y}$
2. $x\ddot{y} - y\ddot{x}$
3. $x\dot{y} - y\dot{x}$
4. $y\dot{x}^2 + x\dot{y}^2$

Q64. [Dec 2019] . 5.0 marks

Classical Mechanics > Canonical transformations

CSIR NET	2019 Dec	5M
----------	----------	----

The generator of the infinitesimal canonical transformation $q \rightarrow q' = (1 + \epsilon)q$ and

$$p \rightarrow p' = (1 - \epsilon)p$$
 is

1. $q + p$
2. qp
3. $\frac{1}{2}(q^2 - p^2)$
4. $\frac{1}{2}(q^2 + p^2)$

Q65. [Dec 2019] . 5.0 marks

Classical Mechanics > Poisson brackets

CSIR NET	2019 Dec	5M
----------	----------	----

The Hamiltonian of a system with two degrees of freedom is $H = q_1 p_1 - q_2 p_2 + a q_1^2$, where $a > 0$ is a constant. The function $q_1 q_2 + \lambda p_1 p_2$ is a constant of motion only if λ is

1. 0
2. 1
3. $-a$
4. a

Q66. [Dec 2019] . 5.0 marks

Classical Mechanics > Basic Mechanics

CSIR NET	2019 Dec	5M
----------	----------	----

The fixed points of the time evolution of a one-variable dynamical system described by

$y_{t+1} = 1 - 2y_t^2$ are 0.5 and -1 . The fixed points 0.5 and -1 are

1. both stable
2. both unstable
3. unstable and stable, respectively
4. stable and unstable, respectively

Q67. [Dec 2019] . 5.0 marks

Classical Mechanics > Basic Mechanics

CSIR NET	2019 Dec	5M
----------	----------	----

Following a nuclear explosion, a shock wave propagates radially outwards. Let E be the energy released in the explosion and ρ be the mass density of the ambient air. Ignoring the temperature of the ambient air, using dimensional analysis, the functional dependence of the radius R of the shock front on E , ρ and the time t is

1. $\left(\frac{Et^2}{\rho}\right)^{1/5}$

2. $\left(\frac{\rho}{Et^2}\right)^{1/5}$

3. $\frac{Et^2}{\rho}$

4. $E\rho t^2$

Q68. [June 2019] . 3.5 marks

Classical Mechanics > Basic Mechanics

CSIR NET	2019 June	3.5M
----------	-----------	------

An object is dropped on a cushion from a height $10m$ above it. On being hit, the cushion is depressed by $0.1 m$. Assuming that the cushion provides a constant resistive force, the deceleration of the object after hitting the cushion, in terms of the acceleration due to gravity g is

1. $10 g$
2. $50g$
3. $100 g$
4. g

Q69. [June 2019] . 3.5 marks

Classical Mechanics > Pseudo Forces

CSIR NET	2019 June	3.5M
----------	-----------	------

A turn-table is rotating with a constant angular velocity ω_0 . In the rotating frame fixed to the turntable, a particle moves radially outwards at a constant speed v_0 . The acceleration of the particle in the $r\theta$ coordinates, as seen from an inertial frame, the origin of which is at the centre of the turntable, is

1. $-r\omega_0^2\hat{r}$
2. $2r\omega_0^2\hat{r} + v_0\omega_0\hat{\theta}$
3. $r\omega_0^2\hat{r} + 2v_0\omega_0\hat{\theta}$
4. $-r\omega_0^2\hat{r} + 2v_0\omega_0\hat{\theta}$

Q70. [June 2019] . 3.5 marks

Classical Mechanics > Central forces

CSIR NET	2019 June	3.5M
----------	-----------	------

Assume that the earth revolves in a circular orbit around the sun. Suppose the gravitational constant G varies slowly as a function of time. In particular, it decreases to half its initial value in the course of one million years. Then during this time the

1. radius of the earth's orbit will increase by a factor of two
2. total energy of the earth remains constant
3. orbital angular momentum of the earth will increase
4. radius of the earth's orbit remains the same.

Q71. [June 2019] . 3.5 marks

Classical Mechanics > Oscillations

CSIR NET	2019 June	3.5M
----------	-----------	------

A particle of mass m moves in One dimension in the potential $V(x) = kx^4$, ($k > 0$). at time $t = 0$ the particle starts from rest at $x = A$. For bounded motion, the time period of its motion is

1. proportional to $A^{-1/2}$
2. proportional to A^{-1}
3. independent of A
4. not well-defined (the system is chaotic)

Q72. [June 2019] . 5.0 marks

Classical Mechanics > Basic Mechanics

CSIR NET

2019 June

5M

A solid spherical Cork of radius R and specific gravity 0.5 floats on water. The cork is pushed down so that its centre of mass is at a distance h (where $0 < h < R$) below the surface of water, and Then released. The volume of the part of the cork above water level is $\pi R^3 \left(\frac{2}{3} - \cos\theta_0 + \frac{1}{3} \cos^3\theta_0 \right)$ where θ_0 is the angle as shown in the figure.

At the moment of release, the dependence of the upward force on the cork on h is

1. $\frac{h}{R} - \frac{1}{3} \left(\frac{h}{R} \right)^3$
2. $\frac{h}{R} + \frac{1}{3} \left(\frac{h}{R} \right)^3$
3. $\frac{h}{R} - \frac{2}{3} \left(\frac{h}{R} \right)^3$
4. $\frac{h}{R} + \frac{2}{3} \left(\frac{h}{R} \right)^3$

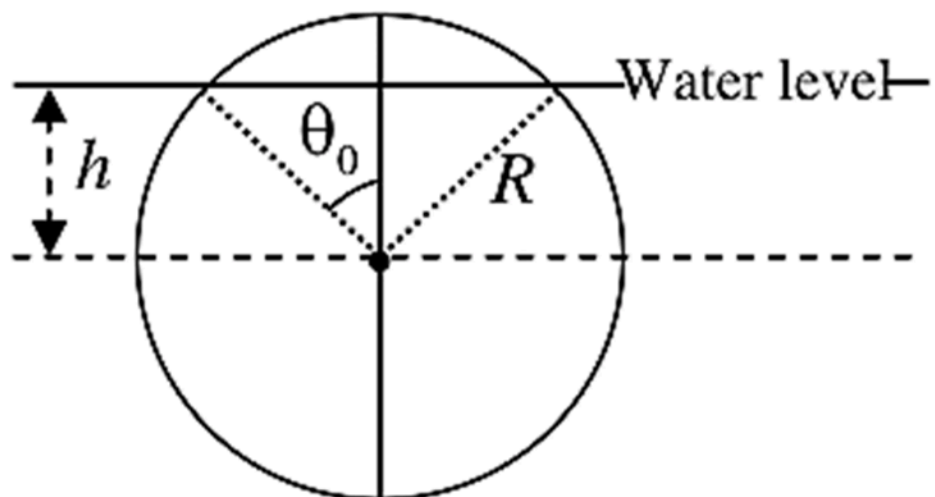

Q73. [June 2019] . 5.0 marks

Classical Mechanics > Lagrangian and Hamiltonian

CSIR NET	2019 June	5M
----------	-----------	----

Two particles of masses m_1 and m_2 are connected by a mass less thread of length l as shown in figure.

The particle of mass m_1 on the plane undergoes a circular motion with radius r_0 and angular momentum L . When a small radial displacement ϵ (where $\epsilon \ll r_0$) is applied, its radial coordinate is found to oscillate about r_0 . The frequency of the oscillations is

1. $\sqrt{\frac{7m_2g}{(m_1 + \frac{m_2}{2})r_0}}$
2. $\sqrt{\frac{7m_2g}{(m_1 + m_2)r_0}}$
3. $\sqrt{\frac{3m_2g}{(m_1 + \frac{m_2}{2})r_0}}$
4. $\sqrt{\frac{3m_2g}{(m_1 + m_2)r_0}}$

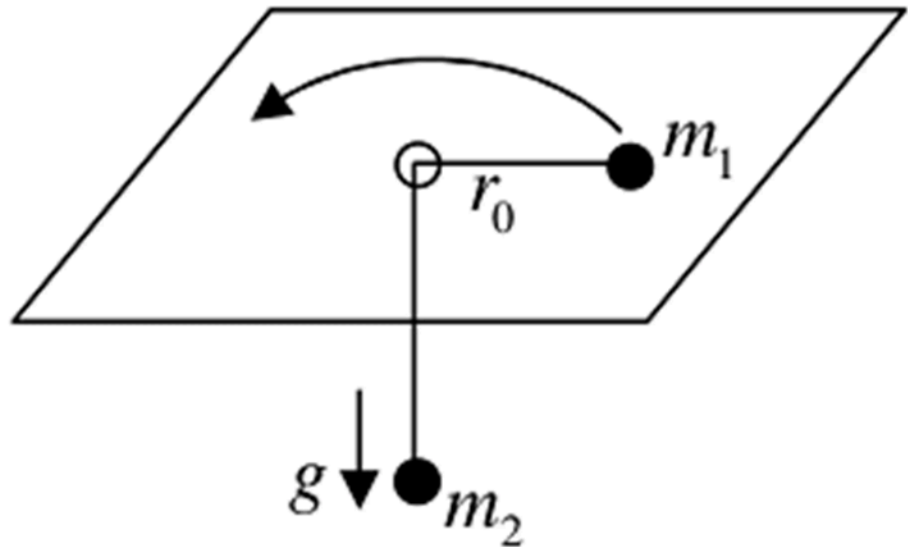

Q74. [June 2019] . 5.0 marks

Classical Mechanics > Basic Mechanics

CSIR NET

2019 June

5M

The time evolution of a coordinate x of a particle is described by the equation

$$\frac{d^2x}{dt^4} + 2\Omega^2 \frac{d^2x}{dt^2} + (\Omega^4 - A^4)x = 0$$

For $\Omega > A$, the particle will

1. eventually come to rest at the origin
2. eventually drift to infinity ($|x| \rightarrow \infty$)
3. oscillate about the origin
4. eventually come to rest at $\frac{\Omega}{A}$ or $-\frac{\Omega}{A}$

Q75. [June 2019] . 5.0 marks

Classical Mechanics > Special theory of relativity

CSIR NET	2019 June	5M
----------	-----------	----

A point charge is moving with a uniform velocity βc along the positive x -direction, parallel to and very close to a corrugated metal sheet (see the figure).

The wavelength of the electromagnetic radiation received by an observer along the direction of motion is

1. $\frac{1}{\beta} \sqrt{1 - \beta^2}$
2. $L \sqrt{1 - \beta^2}$
3. $L \beta \sqrt{1 - \beta^2}$
4. L

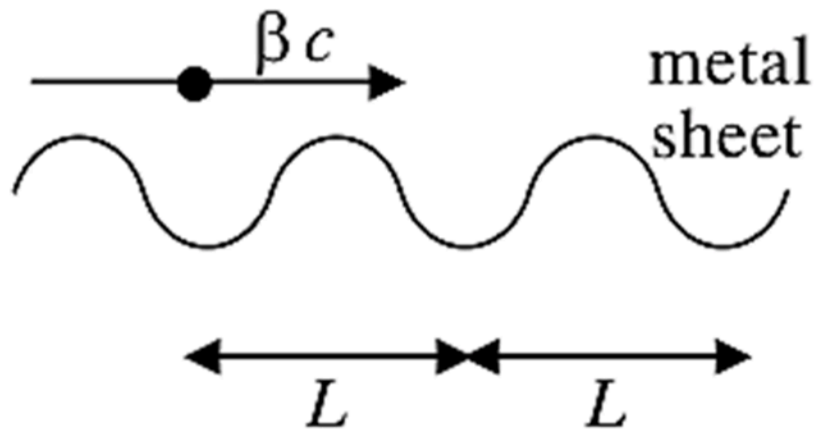

Q76. [June 2019] . 5.0 marks

Classical Mechanics > Oscillations

CSIR NET	2019 June	5M
----------	-----------	----

The equation of motion of a forced simple harmonic oscillator is $\ddot{x} + \omega^2 x = A \cos \Omega t$, where A is a constant. At resonance $\Omega = \omega$ the amplitude of oscillations at large times

1. saturates to a finite value
2. increases with time as \sqrt{t}
3. increases linearly with time
4. increases exponentially with time

Q77. [June 2020] . 3.5 marks

Classical Mechanics > Lagrangian and Hamiltonian

CSIR NET	2020 June	3.5M
----------	-----------	------

A point mass m , is constrained to move on the inner surface of a paraboloid of revolution $x^2 + y^2 = az$ (where $a > 0$ is a constant). When it spirals down the surface, under the influence of gravity (along $-z$ direction), the angular speed about the z - axis is proportional to

1. 1 (independent of z)
2. Z
3. Z^{-1}
4. z^{-2}

Q78. [June 2020] . 3.5 marks

Classical Mechanics > Oscillations

CSIR NET	2020 June	3.5M
----------	-----------	------

Two coupled oscillators in a potential $V(x,y) = \frac{1}{2}kx^2 + 2xy + \frac{1}{2}ky^2$ ($k > 2$) can be decoupled into two independent harmonic oscillators (coordinates: x', y') by means of an appropriate transformation $\begin{pmatrix} x' \\ y' \end{pmatrix} = S \begin{pmatrix} x \\ y \end{pmatrix}$. The transformation matrix S is

1.
$$\begin{pmatrix} \frac{1}{\sqrt{2}} & 1 \\ 1 & -\frac{1}{\sqrt{2}} \end{pmatrix}$$

2.
$$\begin{pmatrix} \frac{1}{\sqrt{2}} & -\frac{1}{\sqrt{2}} \\ \frac{1}{\sqrt{2}} & \frac{1}{\sqrt{2}} \end{pmatrix}$$

3.
$$\begin{pmatrix} \frac{1}{\sqrt{2}} & -\frac{1}{\sqrt{2}} \\ -\frac{1}{\sqrt{2}} & \frac{1}{\sqrt{2}} \end{pmatrix}$$

4.
$$\begin{pmatrix} 0 & -1 \\ 1 & 0 \end{pmatrix}$$

Q79. [June 2020] . 3.5 marks

Classical Mechanics > Special theory of relativity

CSIR NET	2020 June	3.5M
----------	-----------	------

A heavy particle of rest mass M while moving along the positive z - direction, decays into two identical light particles with rest mass m (where $M > 2m$). The maximum value of the momentum that any one of the lighter particles can have in a direction perpendicular to the z direction, is

1. $\frac{1}{2} C\sqrt{M^2 - 4m^2}$

2. $\frac{1}{2} C\sqrt{M^2 - 2m^2}$

3. $C\sqrt{M^2 - 4m^2}$

4. $\frac{1}{2} MC$

Q80. [June 2020] . 3.5 marks

Classical Mechanics > Rotation Motion

CSIR NET	2020 June	3.5M
----------	-----------	------

A frictionless horizontal circular table is spinning with a uniform angular velocity ω about the vertical axis through its centre. If a ball of radius a is placed on it at a distance r from the centre of the table, its linear velocity will be

1. $-r\omega\hat{r} + a\omega\hat{\theta}$
2. $r\omega\hat{r} + a\omega\hat{\theta}$
3. $a\omega\hat{r} + r\omega\hat{\theta}$
4. 0 (zero)

Q81. [June 2020] . 5.0 marks

Classical Mechanics > Basic Mechanics

CSIR NET	2020 June	5M
----------	-----------	----

Falling drops of rain break up and coalesce with each other and finally achieve an approximately spherical shape in the steady state. The radius of such a drop scales with the surface tension σ as

1. $1/\sqrt{\sigma}$
2. $\sqrt{\sigma}$
3. σ
4. σ^2

Q82. [June 2020] . 5.0 marks

Classical Mechanics > Basic Mechanics

CSIR NET	2020 June	5M
----------	-----------	----

The velocity $v(x)$ of a particle moving in one dimension is given by $v(x) = v_0 \sin\left(\frac{\pi x}{x_0}\right)$, where v_0 and x_0 are positive constants of appropriate dimensions. If the particle is initially at $x/x_0 = \epsilon$, where $|\epsilon| \ll 1$, then, in the long time, it

1. Executes an oscillatory motion around $x = 0$
2. Tends towards $x = 0$
3. Tends towards $x = x_0$
4. Executes an oscillatory motion around $x = x_0$

Q83. [June 2020] . 5.0 marks

Classical Mechanics > Oscillations

CSIR NET	2020 June	5M
----------	-----------	----

A pendulum executes small oscillations between angles $+\theta_0$ and $-\theta_0$. If $\tau(\theta)d\theta$ is the time spent between θ and $\theta + d\theta$, then $\tau(\theta)$ is best represented by

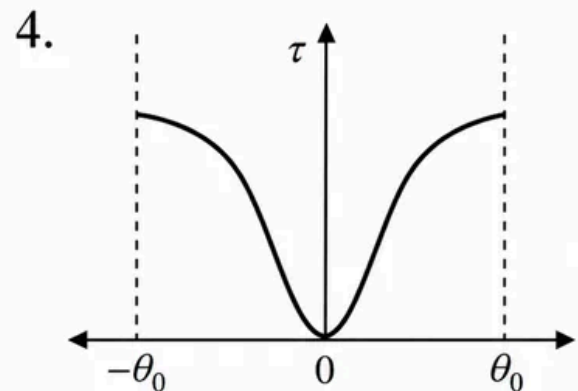
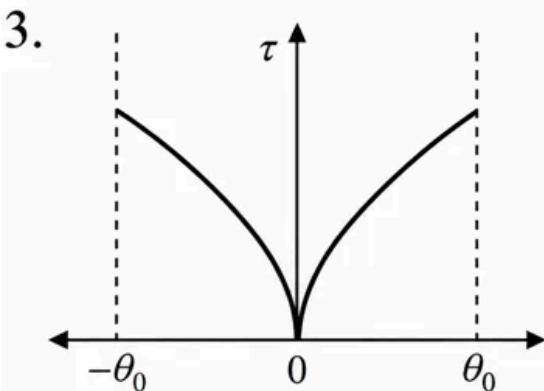
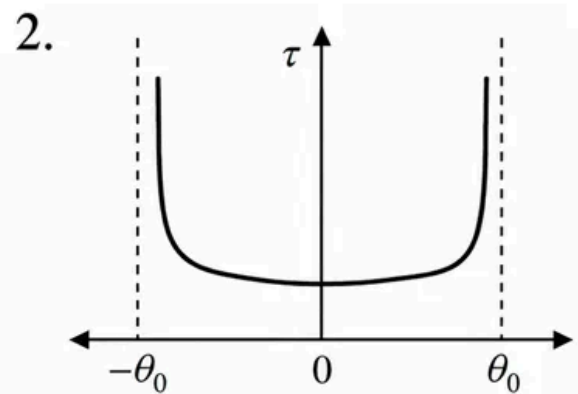
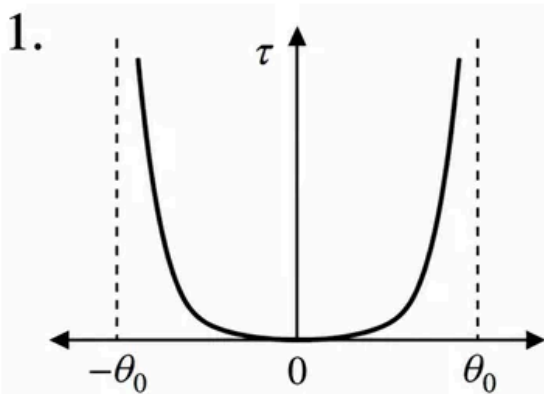

Q84. [June 2020] . 5.0 marks

Classical Mechanics > Phase space diagrams

CSIR NET	2020 June	5M
----------	-----------	----

Consider a particle with total energy E moving in one dimension in a potential $V(x)$ as shown in the figure below.

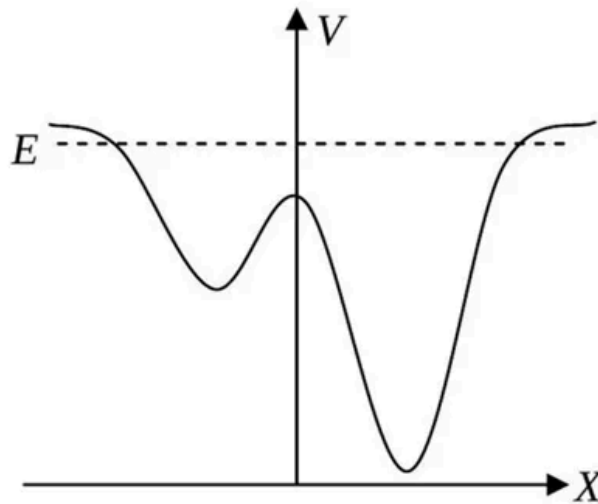

Which of the following figures best represents the orbit of the particle in the phase space?

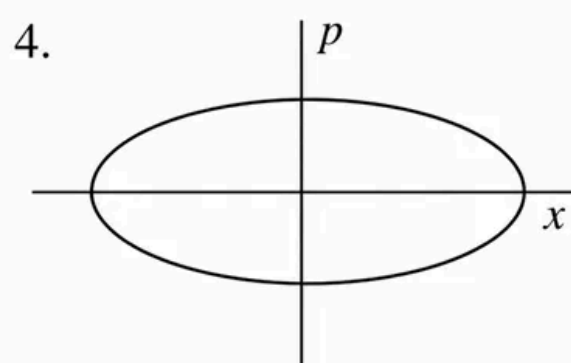
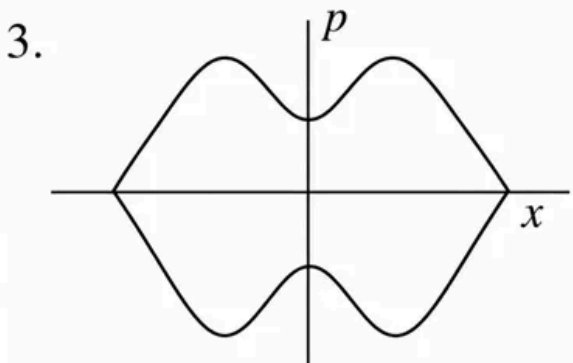
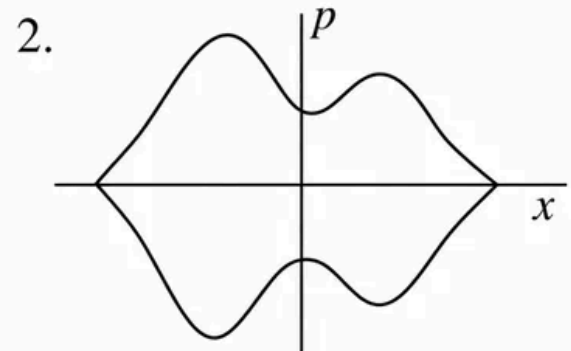
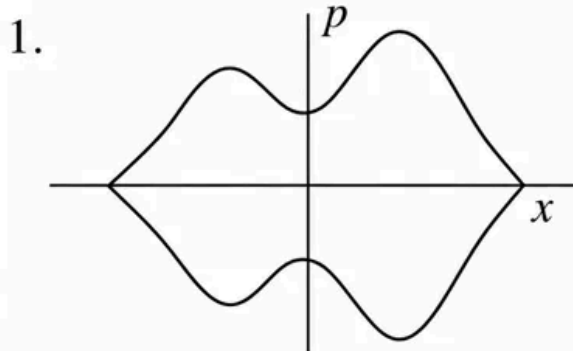

Q85. [June 2021] . 3.5 marks

Classical Mechanics > Oscillations

CSIR NET	2021 June	3.5M
----------	-----------	------

A particle in one dimension executes oscillatory motion in a potential $V(x) = A|x|$, where $A > 0$ is a constant of appropriate dimension. If the time period T of its oscillation depends on the total energy E as E^a , then the value of a is

1. $1/3$
2. $1/2$
3. $2/3$
4. $3/4$

Q86. [June 2021] . 3.5 marks

Classical Mechanics > Central forces

CSIR NET	2021 June	3.5M
----------	-----------	------

A particle, thrown with a speed v from the earth's surface, attains a maximum height h (measured from the surface of the earth). If v is half the escape velocity and R denotes the radius of earth, then h/R is

1. $2/3$
2. $1/3$
3. $1/4$
4. $1/2$

Q87. [June 2021] . 3.5 marks

Classical Mechanics > Special theory of relativity

CSIR NET	2021 June	3.5M
----------	-----------	------

A particle of mass $1 \text{ GeV}/c^2$ and its antiparticle, both moving with the same speed v , produce new particle x of mass $10 \text{ GeV}/c^2$ in a head on collision. The minimum value of v required for this process is closest to

1. $0.83c$
2. $0.93c$
3. $0.98c$
4. $0.88c$

Q88. [June 2021] . 3.5 marks

Classical Mechanics > Special theory of relativity

CSIR NET	2021 June	3.5M
----------	-----------	------

A monochromatic source emitting radiation with a certain frequency moves with a velocity v away from a stationary observer A. It is moving towards another observer B (also at rest) along a line joining the two. The frequencies of the radiation recorded by A and B are V_A and V_B , respectively. If the ratio

$\frac{V_B}{V_A} = 7$, then the value of v/c is

1. $1/2$
2. $1/4$
3. $3/4$
4. $\sqrt{3}/2$

Q89. [June 2021] . 5.0 marks

Classical Mechanics > Oscillations

CSIR NET	2021 June	5M
----------	-----------	----

A particle of mass m moves in a potential that is $V = \frac{1}{2} m(\omega_1^2 x^2 + \omega_2^2 y^2 + \omega_3^2 z^2)$ in the coordinates of a non-inertial frame F . The frame F is rotating with respect to an inertial frame with an angular velocity $\hat{k}\Omega$, where \hat{k} it is the unit vector along their common z -axis. The motion of the particle is unstable for all angular frequencies satisfying

1. $(\Omega^2 - \omega_1^2)(\Omega^2 - \omega_2^2) > 0$
2. $(\Omega^2 - \omega_1^2)(\Omega^2 - \omega_2^2) < 0$
3. $(\Omega^2 - (\omega_1 + \omega_2)^2)(\Omega^2 - |\omega_1 - \omega_2|^2) > 0$
4. $(\Omega^2 - (\omega_1 + \omega_2)^2)(\Omega^2 - |\omega_1 - \omega_2|^2) < 0$

Q90. [June 2021] . 5.0 marks

Classical Mechanics > Central forces

CSIR NET	2021 June	5M
----------	-----------	----

A particle in two dimensions is found to trace an orbit $r(\theta) = r_0\theta^2$. If it is moving under the influence of a central potential $V(r) = c_1r^{-a} + c_2r^{-b}$, where r_0, c_1 and c_2 are constants of appropriate dimensions, the values of a and b , respectively, are

1. 2 and 4
2. 2 and 3
3. 3 and 4
4. 1 and 3

Q91. [June 2021] . 5.0 marks

Classical Mechanics > Lagrangian and Hamiltonian

CSIR NET

2021 June

5M

The fulcrum of a simple pendulum (consisting of a particle of mass m attached to the support by a massless string of length ℓ) oscillates vertically as $z(t) = a \sin \omega t$, where ω is a constant. The pendulum moves in a vertical plane and $\theta(t)$ denotes its angular position with respect to the z -axis.

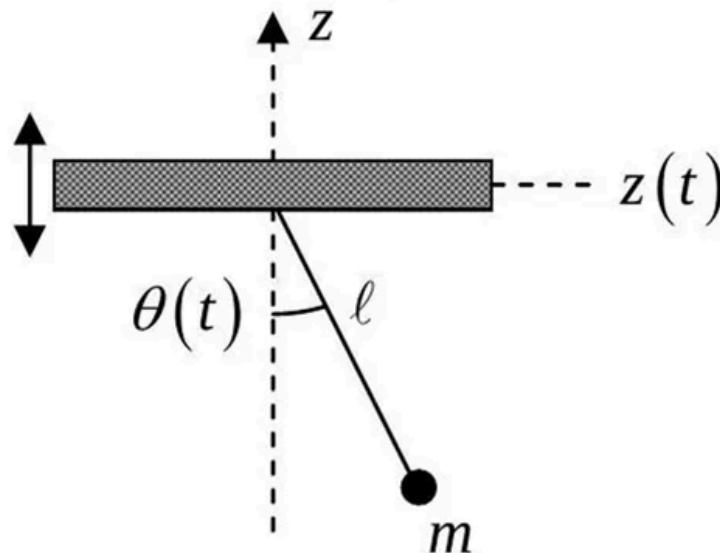

If $\ell \frac{d^2\theta}{dt^2} + \sin \theta (g - f(t)) = 0$ (where g is the acceleration due to gravity) describes the equation of motion of the mass, then $f(t)$ is

1. $a\omega^2 \cos \omega t$
2. $a\omega^2 \sin \omega t$
3. $-a\omega^2 \cos \omega t$
4. $-a\omega^2 \sin \omega t$

Q92. [June 2021] . 5.0 marks

Classical Mechanics > Central forces

CSIR NET	2021 June	5M
----------	-----------	----

A satellite of mass m orbits around earth in an elliptic trajectory of semi-major axis a . At a radial distance $r = r_0$, measured from the centre of the earth, the kinetic energy is equal to half the magnitude of the total energy. If M denotes the mass of the earth and the total energy is $-\frac{GMm}{2a}$, the value of r_0/a is nearest to

1. 1.33
2. 1.48
3. 1.25
4. 1.67

Q93. [June 2022] . 3.5 marks

Classical Mechanics > Oscillations

CSIR NET

2022 June

3.5M

A wire, connected to a massless spring of spring constant k and a block of mass m , goes around a disc of radius a and moment of inertia I , as shown in the figure. Assume that the spring remains horizontal, the pulley rotates freely and there is no slippage between the wire and the pulley. The angular frequency of small oscillations of the disc is

1. $\sqrt{\frac{2ka^2}{ma^2+I}}$

2. $\sqrt{\frac{ka^2}{ma^2+I}}$

3. $\sqrt{\frac{ka^2}{ma^2+2I}}$

4. $\sqrt{\frac{ka^2}{2ma^2+I}}$

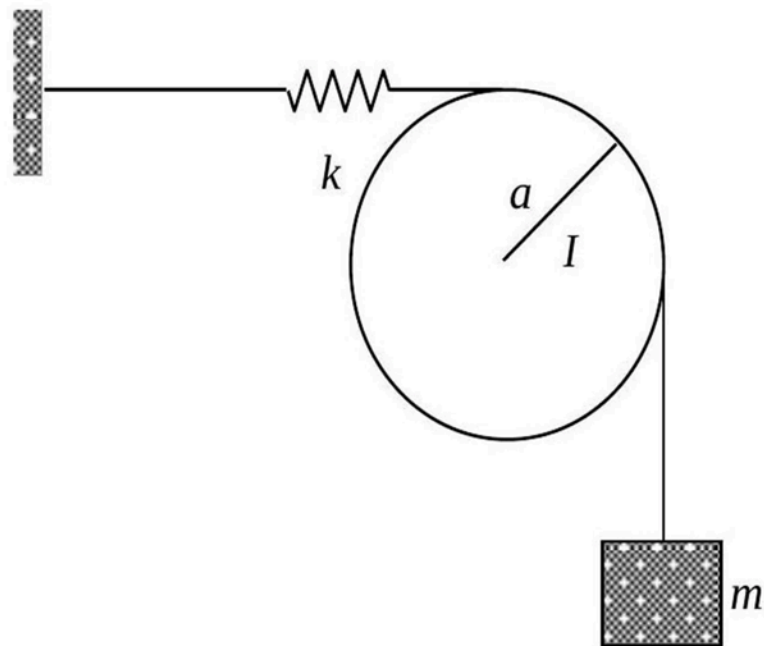

Q94. [June 2022] . 3.5 marks

Classical Mechanics > Lagrangian and Hamiltonian

CSIR NET	2022 June	3.5M
----------	-----------	------

The Lagrangian of a system described by three generalized coordinates q_1, q_2 and q_3 is

$$L = \frac{1}{2}m(\dot{q}_1^2 + \dot{q}_2^2) + M\dot{q}_1\dot{q}_2 + k\dot{q}_1q_3,$$

where m, M and k are positive constants. Then, as a function of time

1. two coordinates remain constant and one evolves linearly
2. one coordinate remains constant, one evolves linearly and the third evolves as a quadratic function
3. one coordinate evolves linearly and two evolve quadratically
4. all three evolve linearly

Q95. [June 2022] . 3.5 marks

Classical Mechanics > Central forces

CSIR NET	2022 June	3.5M
----------	-----------	------

The periods of oscillation of a simple pendulum at the sea level and at the top of a mountain of height 6 km are T_1 and T_2 , respectively. If the radius of earth is approximately 6000 km, then $\frac{(T_2 - T_1)}{T_1}$ is

closest to

1. -10^{-4}
2. -10^{-3}
3. 10^{-4}
4. 10^{-3}

Q96. [June 2022] . 3.5 marks

Classical Mechanics > Special theory of relativity

CSIR NET	2022 June	3.5M
----------	-----------	------

A particle of rest mass m is moving with a velocity $v\hat{k}$, with respect to an inertial frame S . The energy of the particle as measured by an observer S' , who is moving with a uniform velocity $u\hat{i}$ with respect to S (in terms of $\gamma_u = 1/\sqrt{1 - u^2/c^2}$ and $\gamma_v = 1/\sqrt{1 - v^2/c^2}$ is

1. $\gamma_u\gamma_v m(c^2 - uv)$
2. $\gamma_u\gamma_v mc^2$
3. $\frac{1}{2}(\gamma_u + \gamma_v)mc^2$
4. $\frac{1}{2}(\gamma_u + \gamma_v)m(c^2 - uv)$

Q97. [June 2022] . 5.0 marks

Classical Mechanics > Oscillations

CSIR NET	2022 June	5M
----------	-----------	----

The Lagrangian of system of two particles is

$$L = \frac{1}{2}\dot{x}_1^2 + 2\dot{x}_2^2 - \frac{1}{2}(x_1^2 + x_2^2 + x_1x_2).$$

The normal frequencies are best approximated by

1. 1.2 and 0.7
2. 1.5 and 0.5
3. 1.7 and 0.5
4. 1.0 and 0.4

Q98. [June 2022] . 5.0 marks

Classical Mechanics > Phase space diagrams

CSIR NET	2022 June	5M
----------	-----------	----

The Lagrangian of a particle in one dimension is $L = \frac{m}{2} \dot{x}^2 - ax^2 - V_0 e^{-10x}$ where a and V_0 are positive constants. The best qualitative representation of a trajectory in the phase space is

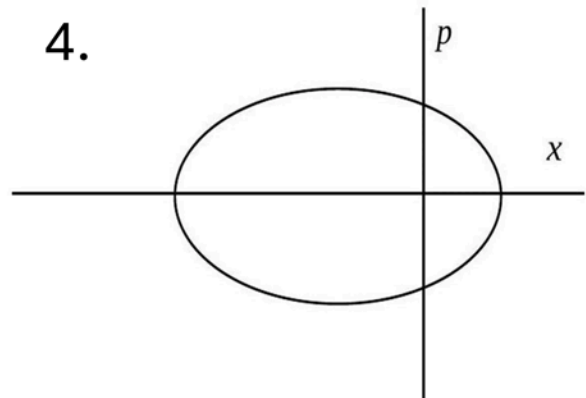
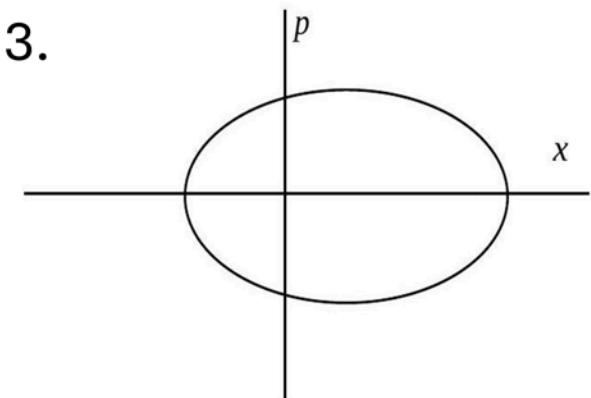
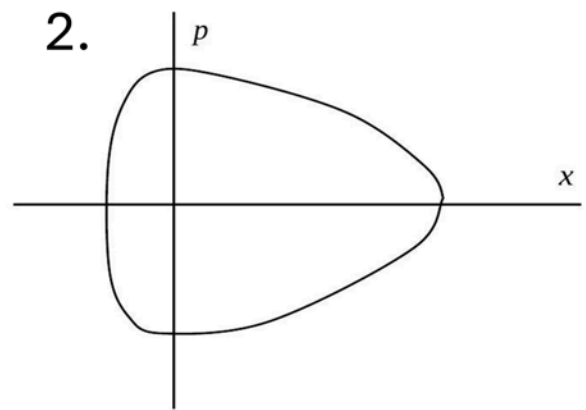
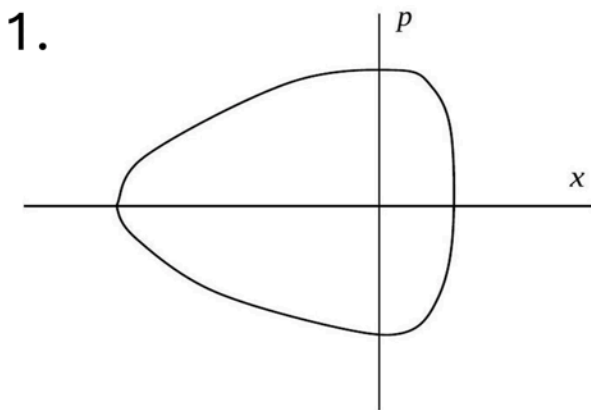

Q99. [June 2022] . 5.0 marks

Classical Mechanics > Rotation Motion

CSIR NET	2022 June	5M
----------	-----------	----

Earth may be assumed to be an axially symmetric freely rotating rigid body. The ratio of the principal moments of inertia about the axis of symmetry and an axis perpendicular to it is 33:32. If T_0 is the time taken by earth to make one rotation around its axis of symmetry, then the time period of precession is closest to

1. $33T_0$
2. $33T_0/2$
3. $32T_0$
4. $16T_0$

Q100. [Dec 2023] . 3.5 marks

Classical Mechanics > Central forces

CSIR NET	2023 Dec	3.5 M
----------	----------	-------

A particle of mass m is moving in a stable circular orbit of radius r_0 with angular momentum L . For a potential energy $V(r) = \beta r^k$ ($\beta > 0$ and $k > 0$), which of the following options is correct?

1. $k = 3, r_0 = \left(\frac{3L^2}{5m\beta}\right)^{1/5}$

2. $k = 2, r_0 = \left(\frac{L^2}{2m\beta}\right)^{1/4}$

3. $k = 2, r_0 = \left(\frac{L^2}{4m\beta}\right)^{1/4}$

4. $k = 3, r_0 = \left(\frac{5L^2}{3m\beta}\right)^{1/5}$

Q101. [Dec 2023] . 3.5 marks

Classical Mechanics > Lagrangian and Hamiltonian

CSIR NET	2023 Dec	3.5 M
----------	----------	-------

The 1-dimensional Hamiltonian of a classical particle of mass m is

$$H = \frac{p^2}{2m} e^{-x/a} + V(x)$$

where a is a constant with appropriate dimensions.

The corresponding Lagrangian is,

1. $\frac{m}{2} \left(\frac{dx}{dt} \right)^2 e^{x/a} - V(x)$
2. $\frac{m}{2} \left(\frac{dx}{dt} \right)^2 e^{-x/a} - V(x)$
3. $\frac{3m}{2} \left(\frac{dx}{dt} \right)^2 e^{x/a} - V(x)$
4. $\frac{3m}{2} \left(\frac{dx}{dt} \right)^2 e^{-x/a} - V(x)$

Q102. [Dec 2023] . 3.5 marks

Classical Mechanics > Oscillations

CSIR NET	2023 Dec	3.5 M
----------	----------	-------

A particle of unit mass subjected to the 1-dimensional potential

$$V(x) = \frac{2\alpha}{x^3} - \frac{3\beta}{x^2}$$

executes small oscillations about its equilibrium position, where α and β are positive constants with appropriate dimensions. The time period of small oscillations is

1. $\frac{\pi\alpha^2}{\sqrt{6\beta^5}}$
2. $\frac{\pi\alpha^2}{\sqrt{3\beta^5}}$
3. $\frac{2\pi\alpha^2}{\sqrt{3\beta^5}}$
4. $\frac{2\pi\alpha^2}{\sqrt{6\beta^5}}$

Q103. [Dec 2023] . 3.5 marks

Classical Mechanics > Special theory of relativity

CSIR NET	2023 Dec	3.5 M
----------	----------	-------

The coordinates of the following events in an observer's inertial frame of reference are as follows:

Event 1: $t_1 = 0, x_1 = 0$: A rocket with uniform velocity $0.5c$ crosses the observer at origin along x axis

Event 2: $t_2 = T, x_2 = 0$: The observer sends a light pulse towards the rocket

Event 3: t_3, x_3 : The rocket receives the light pulse

The values of t_3, x_3 respectively are

1. $2T, cT$

2. $2T, \frac{c}{2}T$

3. $\frac{\sqrt{3}}{2}T, \frac{2}{\sqrt{3}}cT$

4. $\frac{2}{\sqrt{3}}T, \frac{\sqrt{3}}{2}cT$

Q104. [Dec 2023] . 3.5 marks

Classical Mechanics > Central forces

CSIR NET	2023 Dec	3.5 M
----------	----------	-------

A particle moves in a circular orbit under a force field given by $\vec{F}(\vec{r}) = -\frac{k}{r^2}\hat{r}$, where k is a positive constant. If the force changes suddenly to

$\vec{F}(\vec{r}) = -\frac{k}{2r^2}\hat{r}$, the shape of the new orbit would be

1. parabolic
2. circular
3. elliptical
4. hyperbolic

Q105. [Dec 2023] . 5.0 marks

Classical Mechanics > Central forces

CSIR NET	2023 Dec	5 M
----------	----------	-----

A particle of mass m is moving in a 3-dimensional potential

$$\phi(r) = -\frac{k}{r} - \frac{k'}{3r^3}, k, k' > 0$$

For the particle with angular momentum l , the necessary condition to have a stable circular orbit is

1. $kk' < \frac{l^4}{4m^2}$
2. $kk' > \frac{l^4}{4m^2}$
3. $kk' < \frac{l^4}{m^2}$
4. $kk' > \frac{l^4}{m^2}$

Q106. [Dec 2023] . 5.0 marks

Classical Mechanics > Canonical transformations

CSIR NET	2023 Dec	5 M
----------	----------	-----

A canonical transformation from the phase space coordinates (q, p) to (Q, P) is generated by the function

$$\psi(p, Q) = \frac{p^2}{2\omega} \tan 2\pi Q,$$

where ω is a positive constant. The function $\psi(p, Q)$ is related to $F(q, Q)$ by the Legendre transform $\psi = pq - F$, where F is defined by $dF = pdq - PdQ$. If the solution for (P, Q) is

$$P(t) = \frac{\omega}{4\pi} t^2, Q(t) = Q_0 = \text{constant}$$

where t is time, then the solution for (p, q) variables can be written as

1. $p = \frac{\omega t}{2\pi} \cos 2\pi Q_0, q = \frac{t}{2\pi} \sin 2\pi Q_0$
2. $p = -\frac{\omega t}{2\pi} \cos 2\pi Q_0, q = \frac{t}{2\pi} \sin 2\pi Q_0$
3. $p = \frac{\omega t}{2\pi} \sin 2\pi Q_0, q = \frac{t}{2\pi} \cos 2\pi Q_0$
4. $p = -\frac{\omega t}{2\pi} \sin 2\pi Q_0, q = \frac{t}{2\pi} \cos 2\pi Q_0$

Q107. [Dec 2023] . 5.0 marks

Classical Mechanics > Lagrangian and Hamiltonian

CSIR NET	2023 Dec	5 M
----------	----------	-----

A Lagrangian is given by

$$L = \frac{1}{2}m(\dot{x}^2 + \dot{y}\dot{z} + \dot{z}^2) - \alpha(2x + 3y + z)$$

The conserved momentum is

1. $m[2\dot{x} + \dot{z}]$
2. $m[2\dot{x} + \dot{y} + \dot{z}]$
3. $m\left[\dot{x} + \frac{3}{2}\dot{y} + \frac{1}{2}\dot{z}\right]$
4. $m[2\dot{x} + 3\dot{z}]$

Q108. [June 2023] . 3.5 marks

Classical Mechanics > Lagrangian and Hamiltonian

CSIR NET	2023 June	3.5M
----------	-----------	------

A one-dimensional rigid rod is constrained to move inside a sphere such that its two ends are always in contact with the surface. The number of constraints on the Cartesian coordinates of the endpoints of the rod is

1. 3
2. 5
3. 2
4. 4

Q109. [June 2023] . 3.5 marks

Classical Mechanics > Central forces

CSIR NET	2023 June	3.5M
----------	-----------	------

The minor axis of Earth's elliptical orbit divides the area within it into two halves. The eccentricity of the orbit is 0.0167. The difference in time spent by Earth in the two halves is closest to

1. 3.9 days
2. 4.8 days
3. 12.3 days
4. 0 days

Q110. [June 2023] . 3.5 marks

Classical Mechanics > Lagrangian and Hamiltonian

CSIR NET	2023 June	3.5M
----------	-----------	------

The Hamiltonian of a two particle system is $H = p_1 p_2 + q_1 q_2$, where q_1 and q_2 are generalized coordinates and p_1 and p_2 are the respective canonical momenta. The Lagrangian of this system is

1. $\dot{q}_1 \dot{q}_2 + q_1 q_2$
2. $-\dot{q}_1 \dot{q}_2 + q_1 q_2$
3. $-\dot{q}_1 \dot{q}_2 - q_1 q_2$
4. $\dot{q}_1 \dot{q}_2 - q_1 q_2$

Q111. [June 2023] . 3.5 marks

Classical Mechanics > Rotation Motion

CSIR NET	2023 June	3.5M
----------	-----------	------

A uniform circular disc on the xy -plane with its centre at the origin has a moment of inertia I_0 about the x axis. If the disc is set in rotation about the origin with an angular velocity $\omega = \omega_0(\hat{j} + \hat{k})$, the direction of its angular momentum is along

1. $-\hat{i} + \hat{j} + \hat{k}$
2. $-\hat{i} + \hat{j} + 2\hat{k}$
3. $\hat{j} + 2\hat{k}$
4. $\hat{j} + \hat{k}$

Q112. [June 2023] . 3.5 marks

Classical Mechanics > Central forces

CSIR NET	2023 June	3.5M
----------	-----------	------

The trajectory of a particle moving in a plane is expressed in polar coordinates (r, θ) by the equations $r = r_0 e^{\beta t}$ and $\frac{d\theta}{dt} = \omega$, where the parameters r_0, β and ω are positive. Let v_r and a_r denote the velocity and acceleration, respectively, in the radial direction. For this trajectory

1. $a_r < 0$ at all times irrespective of the values of the parameters
2. $a_r > 0$ at all times irrespective of the values of the parameters
3. $\frac{dv_r}{dt} > 0$ and $a_r > 0$ for all choices of parameters
4. $\frac{dv_r}{dt} > 0$, however, $a_r = 0$ for some choices of parameters

Q113. [June 2023] . 5.0 marks

Classical Mechanics > Oscillations

CSIR NET	2023 June	5M
----------	-----------	----

A system of two identical masses connected by identical springs, as shown in the figure, oscillates along the vertical direction. The ratio of the frequencies of the normal modes is

1. $\sqrt{3 - \sqrt{5}} : \sqrt{3 + \sqrt{5}}$
2. $3 - \sqrt{5} : 3 + \sqrt{5}$
3. $\sqrt{5 - \sqrt{3}} : \sqrt{5 + \sqrt{3}}$
4. $5 - \sqrt{3} : 5 + \sqrt{3}$

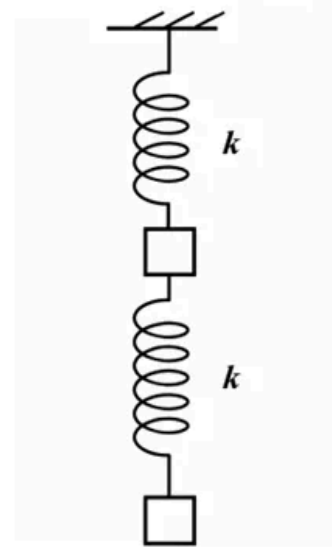

Q114. [June 2023] . 5.0 marks

Classical Mechanics > Canonical transformations

CSIR NET	2023 June	5M
----------	-----------	----

For the transformation $x \rightarrow X = \frac{\alpha p}{x}$, $p \rightarrow P = \beta x^2$ between conjugate pairs of a coordinate and its momentum, to be canonical, the constants α and β must satisfy

1. $1 + \frac{1}{2}\alpha\beta = 0$
2. $1 - \frac{1}{2}\alpha\beta = 0$
3. $1 + 2\alpha\beta = 0$
4. $1 - 2\alpha\beta = 0$

Q115. [Dec 2024] . 3.5 marks

Classical Mechanics > Special theory of relativity

CSIR NET	2024 Dec	3.5M
----------	----------	------

A certain elementary particle is created in the upper atmosphere. It then moves downward with speed $v = 0.9999c$ with respect to an observer on earth. Its lifetime in its rest frame is 2×10^{-6} sec. The distance (in the earth's frame) travelled by the elementary particle before it decays is closest to

1. 0.6 km
2. 42 km
3. 12 km
4. 72 km

Q116. [Dec 2024] . 3.5 marks

Classical Mechanics > Special theory of relativity

CSIR NET	2024 Dec	3.5M
----------	----------	------

A particle of rest mass m_0 and energy E collides with another particle at rest, with the same rest mass. What is the minimum value of E so that after the collision, there may be four particles of rest mass m_0 ?

1. $4m_0c^2$
2. $3m_0c^2$
3. $7m_0c^2$
4. $16m_0c^2$

Q117. [Dec 2024] . 3.5 marks

Classical Mechanics > Lagrangian and Hamiltonian

CSIR NET	2024 Dec	3.5M
----------	----------	------

The point of support of a simple pendulum, of mass m and length l , is attached to the roof of a taxi as shown in the figure. The taxi is moving with uniform velocity v . The Lagrangian for the pendulum is

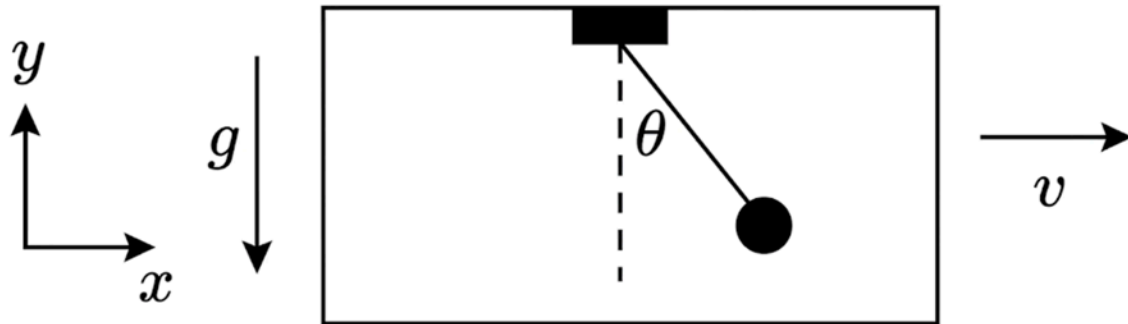

1. $L = \frac{1}{2}ml^2\dot{\theta}^2 + \frac{1}{2}mv^2 + mlv \cos \theta \dot{\theta} - mgl \cos \theta$
2. $L = \frac{1}{2}ml^2\dot{\theta}^2 + \frac{1}{2}mv^2 + mlv \cos \theta \dot{\theta} + mgl \cos \theta$
3. $L = \frac{1}{2}ml^2\dot{\theta}^2 + \frac{1}{2}mv^2 + mlv \sin \theta \dot{\theta} + mgl \cos \theta$
4. $L = \frac{1}{2}ml^2\dot{\theta}^2 + \frac{1}{2}mv^2 + mlv \sin \theta \dot{\theta} - mgl \cos \theta$

Q118. [Dec 2024] . 3.5 marks

Classical Mechanics > Basic Mechanics

CSIR NET	2024 Dec	3.5M
----------	----------	------

Two blocks m_1 and m_2 are in contact on a frictionless horizontal table. A horizontal force is applied to one of the blocks, as shown in the figure.

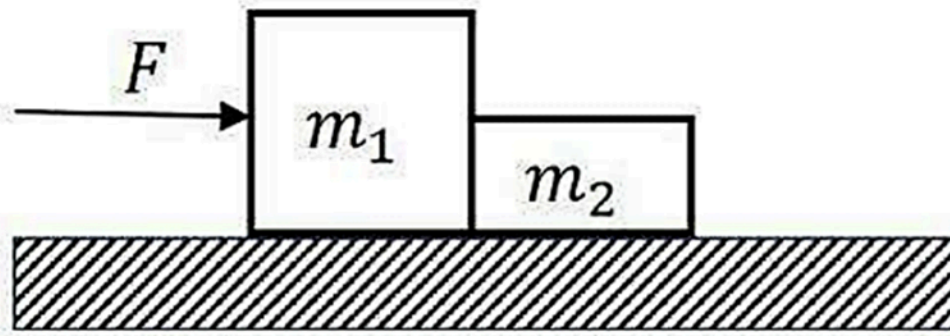

If $m_1 = 2 \text{ kg}$, $m_2 = 1 \text{ kg}$, and $F = 3 \text{ N}$, the force of contact between the blocks is

1. 1 N
2. 2 N
3. 1.5 N
4. 3 N

Q119. [Dec 2024] . 3.5 marks

Classical Mechanics > Basic Mechanics

CSIR NET

2024 Dec

3.5M

A frictionless track is defined by $z = z_0 - \frac{x^2}{4z_0}$, as shown in the figure. A particle is constrained to slide down the track under the action of gravity. The tangential acceleration at position (x, z) would be

1. $\frac{2gx}{\sqrt{x^2 + 4z_0^2}}$

2. $\frac{gx}{\sqrt{x^2 + 4z_0^2}}$

3. $\frac{gx}{2z_0}$

4. $g \sqrt{\frac{x(x + z_0)}{x^2 + 4z_0^2}}$

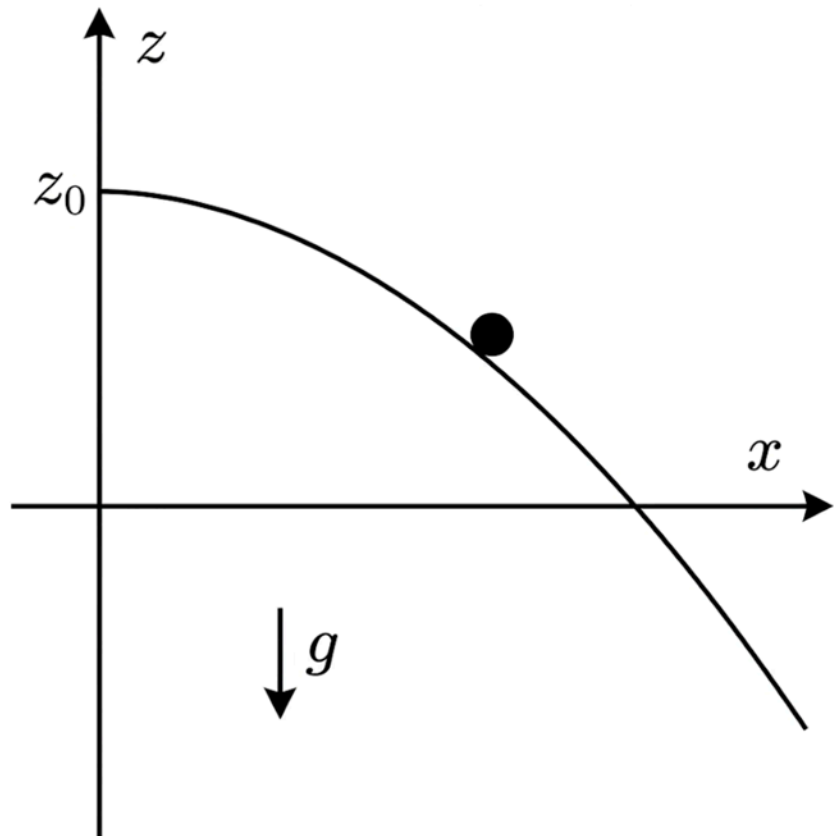

Q120. [Dec 2024] . 5.0 marks

Classical Mechanics > Lagrangian and Hamiltonian

CSIR NET	2024 Dec	5M
----------	----------	----

The Lagrangian of a system is

$$L = \frac{15}{2}m\dot{x}^2 + 6m\dot{x}\dot{y} + 3m\dot{y}^2 - mg(x + 2y)$$

Which one of the following is conserved?

1. $12\dot{x} + 3\dot{y}$
2. $12\dot{x} - 3\dot{y}$
3. $3\dot{x} - 12\dot{y}$
4. $3\dot{x} + 3\dot{y}$

Q121. [Dec 2024] . 5.0 marks

Classical Mechanics > Canonical transformations

CSIR NET	2024 Dec	5M
----------	----------	----

For the transformation

$$Q = \ln(1 + q^{1/2} \cos p), P = 2q^{1/2}(1 + q^{1/2} \cos p) \sin p$$

the generating function is

1. $-(e^Q - 1)^2 \cot p$
2. $(e^Q - 1)^2 \cot p$
3. $(e^Q - 1)^2 \tan p$
4. $-(e^Q - 1)^2 \tan p$

Q122. [Dec 2024] . 5.0 marks

Classical Mechanics > Poisson brackets

CSIR NET	2024 Dec	5M
----------	----------	----

A non-relativistic particle of mass m and charge q is moving in a magnetic field $\vec{B}(x, y, z)$. If \vec{v} denotes its velocity and $\{\dots\}_{P.B.}$ denotes the Poisson Bracket, then $\epsilon_{ijk}\{v_i, v_j\}_{P.B.}$ is equal to

1. $-\frac{q}{m^2}B_k$
2. 0
3. $\frac{2q}{m^2}B_k$
4. $\frac{q}{m^2}B_k$

Q123. [June 2024] . 3.5 marks

Classical Mechanics > Phase space diagrams

CSIR NET	2024 June	3.5M
----------	-----------	------

The evolution of the dynamical variables $x(t)$ and $p(t)$ is given by

$$\dot{x} = ax, \dot{p} = -p$$

where a is a constant. The trajectory in (x, p) space for $-1 < a < 0$ is best described by

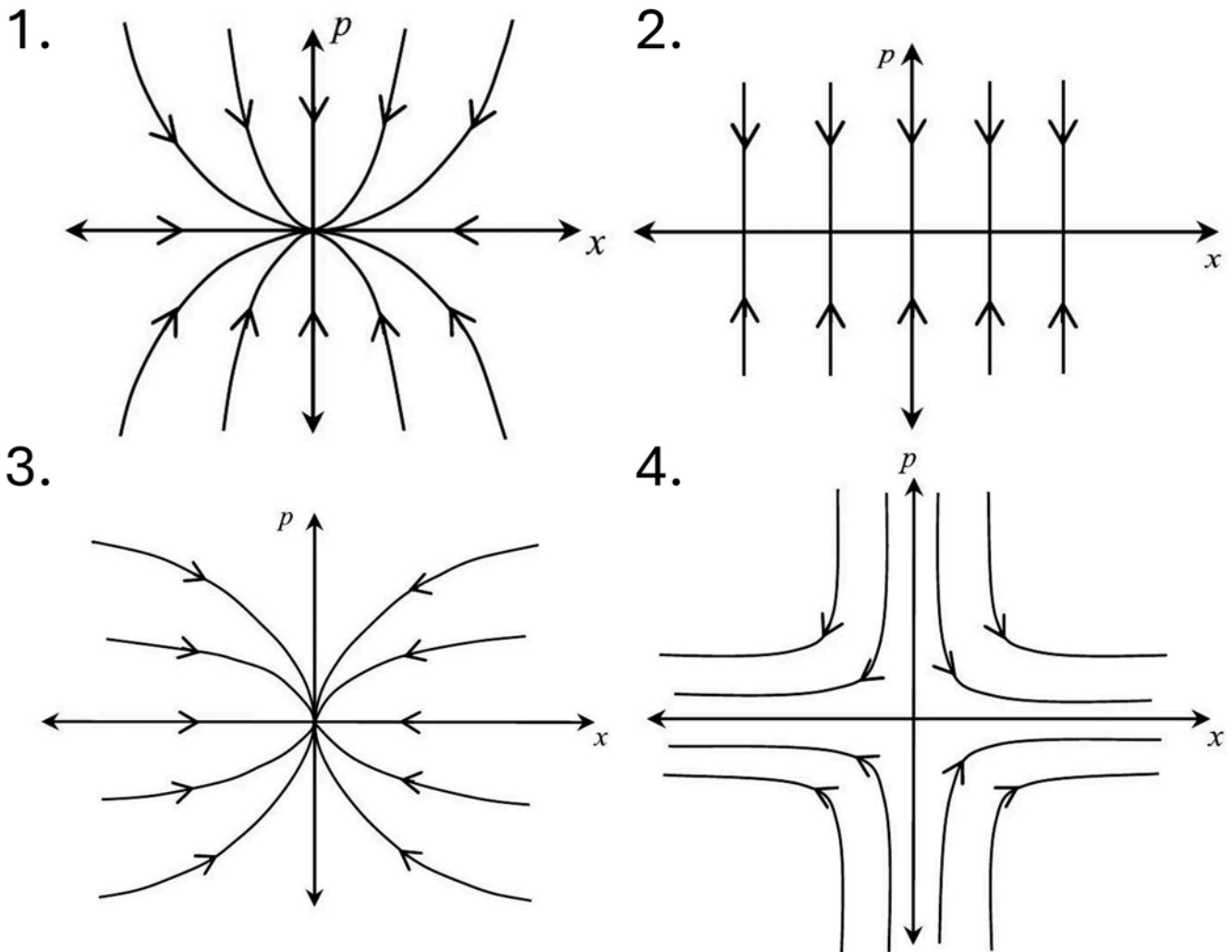

Q124. [June 2024] . 3.5 marks

Classical Mechanics > Rotation Motion

CSIR NET	2024 June	3.5M
----------	-----------	------

A uniform plane square sheet of mass m is centered at the origin of an inertial frame. The sheet is rotating about an axis passing through the origin. At an instant when all its vertices lie on x and y axes, the angular momentum is $\vec{L} = I_0\omega_0(2\hat{i} + \hat{j} + 2\hat{k})$, where I_0 is the moment of inertia about the x axis. At this instant, the angular velocity of the sheet is

1. $(2\hat{i} + \hat{j} + 2\hat{k})\omega_0$
2. $(2\hat{i} + \hat{j} + \hat{k})\omega_0$
3. $(2\hat{i} + \hat{j})\omega_0$
4. $(\hat{i} + \hat{j})\omega_0$

Q125. [June 2024] . 3.5 marks

Classical Mechanics > Central forces

CSIR NET	2024 June	3.5M
----------	-----------	------

A body of mass m is acted upon by a central force $\vec{f}(\vec{r}) = -k\vec{r}$, where k is a positive constant. If the magnitude of the angular momentum is l , then the total energy for a circular orbit is

1. $2\sqrt{\frac{kl^2}{m}}$

2. $\frac{1}{2}\sqrt{\frac{kl^2}{m}}$

3. $\frac{3}{2}\sqrt{\frac{kl^2}{m}}$

4. $\sqrt{\frac{kl^2}{m}}$

Q126. [June 2024] . 3.5 marks

Classical Mechanics > Special theory of relativity

CSIR NET

2024 June

3.5M

A square plate of dimension $a \times a$ makes an angle $\theta = \pi/4$ with the x axis in its rest frame (S) as shown

in the figure. It is moving with a speed $v = \sqrt{\frac{2}{3}}C$ along the x axis with respect to an observer S' (where C is the speed of light in vacuum). The value of the interior angle ϕ indicated in the figure (which is obviously $\pi/2$ in the frame S), as measured in S' is

1. $\frac{\pi}{3}$
2. $\frac{2\pi}{3}$
3. $\frac{\pi}{6}$
4. $\frac{4\pi}{3}$

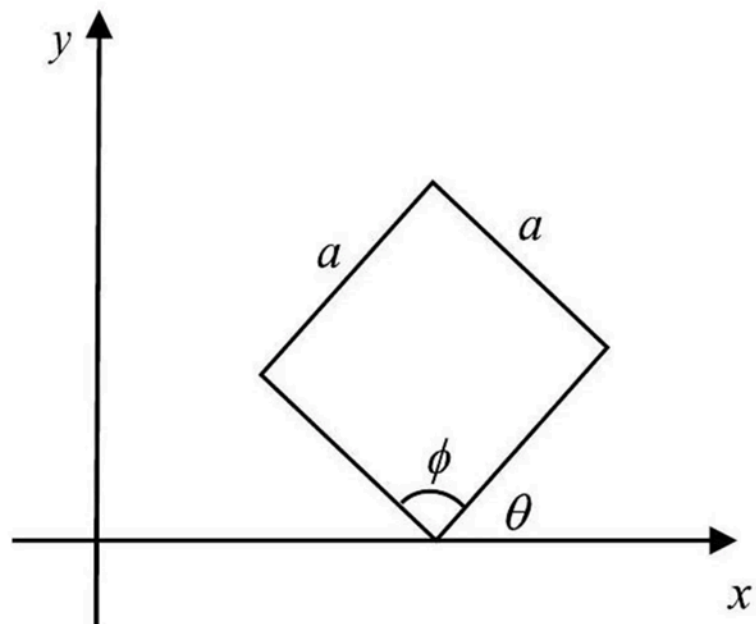

Q127. [June 2024] . 5.0 marks

Classical Mechanics > Central forces

CSIR NET	2024 June	5M
----------	-----------	----

A particle of mass m is moving in a potential $V(r) = -\frac{k}{r}$, where k is a positive constant. If \vec{L} and \vec{p} denote the angular momentum and linear momentum respectively, the value of α for which $\vec{A} = \vec{L} \times \vec{p} + \alpha mk\hat{r}$ is a constant of motion, is

1. -2
2. -1
3. 2
4. 1

Q128. [June 2024] . 5.0 marks

Classical Mechanics > Oscillations

CSIR NET	2024 June	5M
----------	-----------	----

A linear molecule is modelled as two atoms of equal mass m placed at coordinates x_1 and x_2 , connected by a spring of spring constant k . The molecule is moving in one dimension under an additional external potential $V(x_1, x_2) = \frac{1}{2}m\omega_0^2(x_1^2 + x_2^2)$. If one frequency of molecular vibration is ω_0 , the other frequency is

1. $\sqrt{\omega_0^2 - \frac{k}{m}}$

2. $\sqrt{\omega_0^2 + \frac{k}{m}}$

3. $\sqrt{\omega_0^2 + \frac{2k}{m}}$

4. $\sqrt{\omega_0^2 - \frac{2k}{m}}$

Q129. [June 2024] . 5.0 marks

Classical Mechanics > Poisson brackets

CSIR NET	2024 June	5M
----------	-----------	----

For a simple harmonic oscillator, the Lagrangian is given by

$$L = \frac{1}{2} \dot{q}^2 - \frac{1}{2} q^2$$

If $H(q, p)$ is the Hamiltonian of the system and

$A(p, q) = \frac{1}{\sqrt{2}} (p + iq)$, the Poisson bracket $\{A, H\}$ is

1. iA
2. A^*
3. $-iA^*$
4. $-iA$

Q130. [June 2024] . 5.0 marks

Classical Mechanics > Oscillations

CSIR NET	2024 June	5M
----------	-----------	----

Three identical simple pendula (of mass m and equilibrium string length l) are attached together by springs of spring constant k , as shown in the figure.

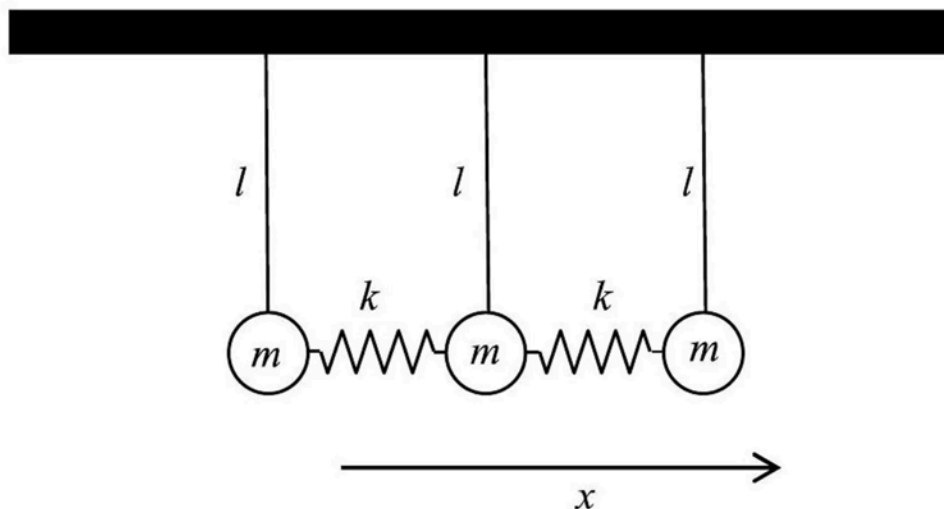

The frequencies of small oscillations are given by

$\sqrt{\frac{g}{l}}$, $\sqrt{\frac{k}{m} + \frac{g}{l}}$, $\sqrt{\frac{3k}{m} + \frac{g}{l}}$. The normal modes (without normalisation) corresponding to these frequencies respectively are

1. $(1,1,1)$, $(1,0,1)$, $(1, -2,1)$
2. $(1,1,1)$, $(1,0, -1)$, $(1,2,1)$
3. $(1,1,1)$, $(1,0, -1)$, $(1, -2,1)$
4. $(1,2,1)$, $(1,0, -1)$, $(1,1,1)$

Q131. [Dec 2025] . 3.5 marks

Classical Mechanics > Rotation Motion

CSIR NET	2025 Dec	3.5M	CM
----------	----------	------	----

A fly of mass m rests on the edge of a uniform horizontal disc of radius R and mass M . The disc is free to rotate about the vertical axis through its center. Initially the disc is stationary. The fly starts to walk around the circumference of the disc with speed v relative to the disc. The speed of the fly for a stationary observer is

1. $\frac{mv}{M+2m}$
2. $\frac{Mv}{M-2m}$
3. $\frac{Mv}{M+2m}$
4. $\frac{mv}{M-2m}$

Q132. [Dec 2025] . 3.5 marks

Classical Mechanics > Rotation Motion

CSIR NET	2025 Dec	3.5M	CM
----------	----------	------	----

The position and velocity vector of a particle changes from \vec{R}_1 to \vec{R}_2 and \vec{V}_1 to \vec{V}_2 as time changes from t_1 to t_2 . If $\vec{r}(t), \vec{a}(t)$ are instantaneous position and acceleration vectors of the particle then the integral

$$I = \int_{t_1}^{t_2} dt(\vec{r}(t) \times \vec{a}(t)) \text{ is}$$

1. $\vec{R}_2 \times \vec{V}_1 - \vec{R}_1 \times \vec{V}_2$
2. $\vec{R}_2 \times \vec{V}_2 - \vec{R}_1 \times \vec{V}_1$
3. $\vec{R}_1 \times \vec{V}_1 - \vec{R}_2 \times \vec{V}_2$
4. $\vec{R}_1 \times \vec{V}_2 - \vec{R}_2 \times \vec{V}_1$

Q133. [Dec 2025] . 3.5 marks

Classical Mechanics > Phase space diagrams

CSIR NET	2025 Dec	3.5M	CM
----------	----------	------	----

Which of the following figures best represents the motion of an oscillator described by the differential equation $\ddot{q} + \dot{q} + q = 0$ in $q - \dot{q}$ plane?

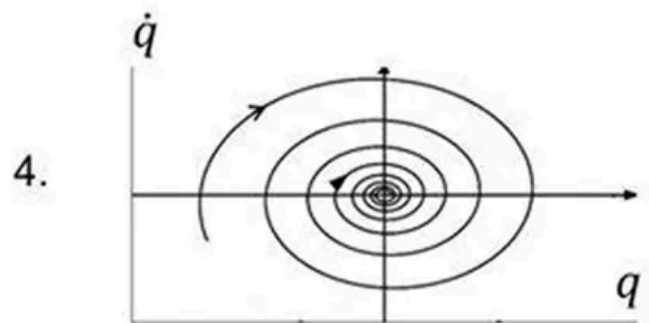
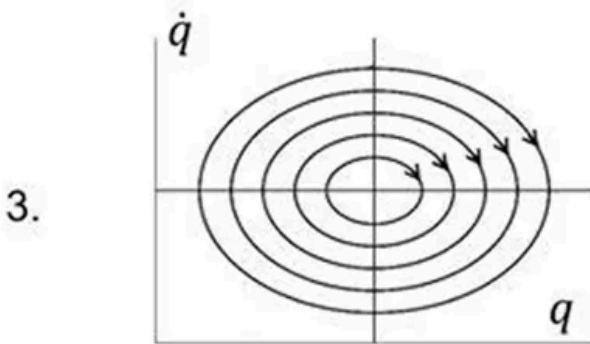
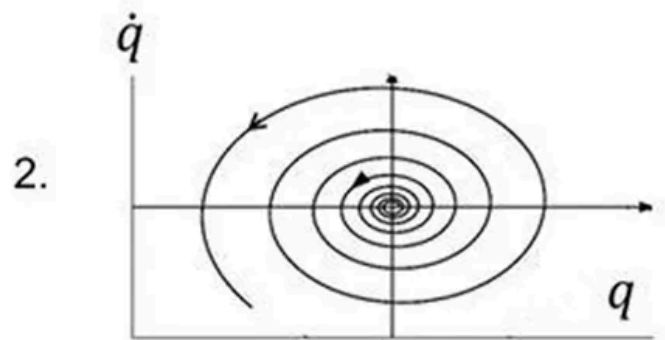
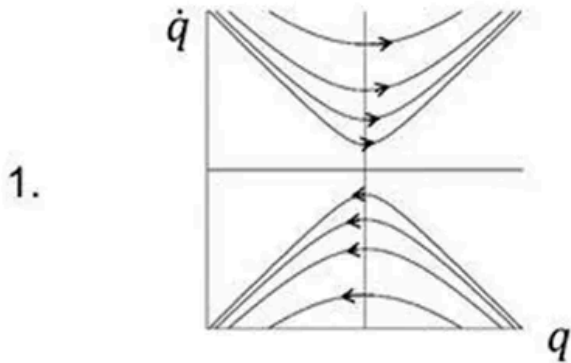

Q134. [Dec 2025] . 3.5 marks

Classical Mechanics > Basic Mechanics

CSIR NET	2025 Dec	3.5M	Wave/Optic
----------	----------	------	------------

A bow has a taut string of tension T_0 (when it is at rest). The string is pulled and released at time $t = 0$. Which plot best represents the tension in the bow string as a function of time?

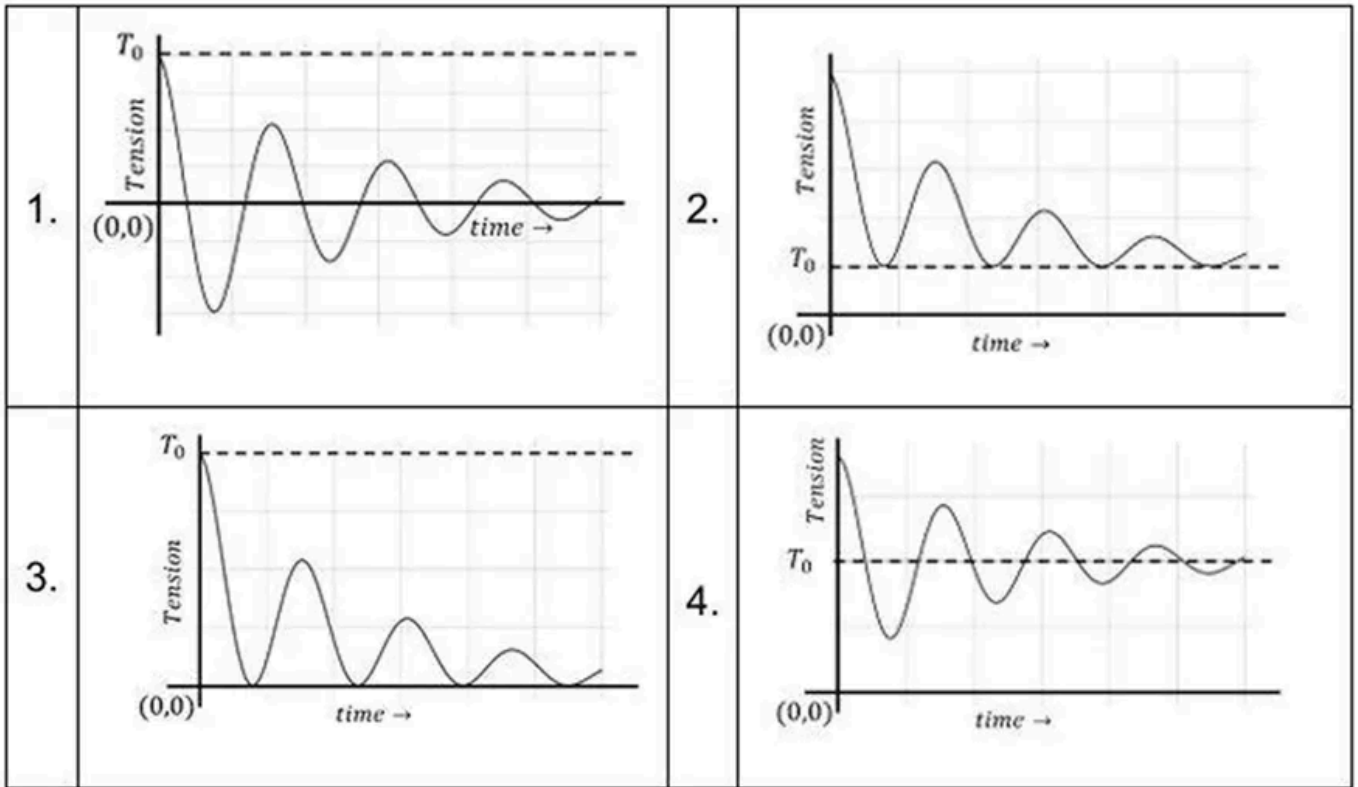

Q135. [Dec 2025] . 5.0 marks

Classical Mechanics > Canonical transformations

CSIR NET	2025 Dec	5M	MMP
----------	----------	----	-----

The Lagrangian $L = L(x, y, \dot{x}, \dot{y})$ is invariant under the transformation $x \rightarrow x + \epsilon y$ and $y \rightarrow y + \epsilon x$, for any infinitesimal real parameter ϵ .

If P_x, P_y denote canonically conjugate momenta corresponding to x, y respectively, then the corresponding conserved quantity is

1. $yP_x - xP_y$
2. $yP_x + xP_y$
3. $xP_x + yP_y$
4. $xP_x - yP_y$

Q136. [Dec 2025] . 5.0 marks

Classical Mechanics > Special theory of relativity

CSIR NET	2025 Dec	5M	CM
----------	----------	----	----

In a high energy scattering experiment involving two identical particles, each of rest mass m_0 , one particle is initially at rest, while the other one is incident upon it with energy E and momentum p . The total energy of the two-particle system in the centre-of-mass frame, in the limit $E \gg m_0 c^2$, is approximately given by

1. E

2. $2E$

3. $\sqrt{\frac{Em_0c^2}{2}}$

4. $\sqrt{2Em_0c^2}$

Q137. [Dec 2025] . 5.0 marks

Classical Mechanics > Oscillations

CSIR NET	2025 Dec	5M	CM
----------	----------	----	----

The Lagrangian of a two-particle system is given by

$$L = \frac{1}{2}m(\dot{q}_1^2 + \dot{q}_2^2 + \dot{q}_1\dot{q}_2) - \frac{1}{2}m\omega^2\left(q_1^2 + q_2^2 + \frac{1}{2}q_1q_2\right).$$

The normal mode frequencies (in units of ω) are

1. $\sqrt{\frac{5}{3}}, \frac{1}{2}$

2. $\sqrt{\frac{5}{6}}, \sqrt{\frac{3}{2}}$

3. $\sqrt{\frac{6}{5}}, \sqrt{2}$

4. $\sqrt{\frac{5}{6}}, \sqrt{2}$

Q138. [Dec 2025] . 5.0 marks

Classical Mechanics > Lagrangian and Hamiltonian

CSIR NET	2025 Dec	5M	CM
----------	----------	----	----

The Hamiltonian of a simple pendulum consisting of mass m attached to a massless string of length l

is $H = \frac{P_\theta^2}{2ml^2} + mgl(1 - \cos\theta)$. If L denotes the

Lagrangian, then $\frac{dL}{dt}$ is

1. $\frac{g}{l} P_\theta \cos\theta$

2. $\frac{-g}{l} P_\theta \sin\theta$

3. $\frac{-2g}{l} P_\theta \sin\theta$

4. $\frac{g}{l} P_\theta \cos(2\theta)$

Q139. [June 2025] . 3.5 marks

Classical Mechanics > Basic Mechanics

[image unavailable]

Q140. [June 2025] . 3.5 marks

Classical Mechanics > Basic Mechanics

CSIR NET	2025 June	3.5M	CM
-----------------	------------------	-------------	-----------

A particle of mass m is subjected to a potential $V(x) = V_0\Theta(x) - kx$, where V_0 and k are positive constants and V_0 is much larger than the energy of the particle. The function $\Theta(x) = 1$ for $x \geq 0$ and equals 0 otherwise. The particle starts from rest at $t = 0$ and $x = -5$. In the limit $V_0 \rightarrow \infty$, the graph for $\dot{x}(t)$ is best represented by

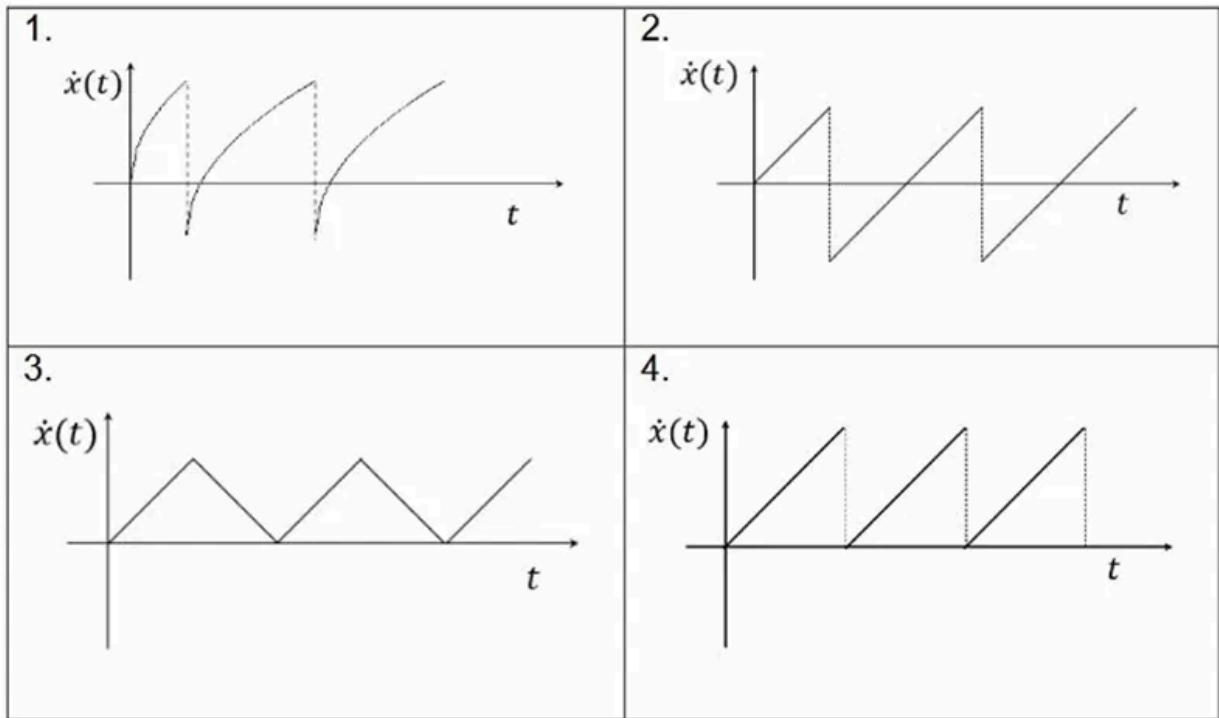

Q141. [June 2025] . 3.5 marks

Classical Mechanics > Lagrangian and Hamiltonian

CSIR NET	2025 June	3.5M	CM
----------	-----------	------	----

The Hamiltonian of a system is given by

$$H(x, p) = -[p^2 + V^2(x)]^{1/2}, \text{ where } x \text{ and } p \text{ are}$$

generalized co-ordinate and momentum

respectively and $V(x) \geq 0$. The corresponding

Lagrangian is

1. $-V(x)\sqrt{1 - \dot{x}^2}$
2. $-V(x)/\sqrt{1 - \dot{x}^2}$
3. $V(x)\sqrt{1 - \dot{x}^2}$
4. $V(x)/\sqrt{1 - \dot{x}^2}$

Q142. [June 2025] . 3.5 marks

Classical Mechanics > Rotation Motion

CSIR NET	2025 June	3.5M	CM
----------	-----------	------	----

Consider the earth to be a free rigid body symmetric about its north-south (z) axis. If the principal moments of inertia satisfy $I_z = 1.003I_x$, then its angular velocity (in the body fixed frame) would precess about the z -axis with a period of nearly

1. 167 days
2. 333 days
3. 556 days
4. 667 days

Q143. [June 2025] . 5.0 marks

Classical Mechanics > Poisson brackets

CSIR NET	2025 June	5M	CM
----------	-----------	----	----

For a free particle of mass m , consider the following time dependent quantity in phase space

$$Q = \frac{qp}{m} - \frac{p^2 t}{m^2},$$

where q and p are the canonically conjugate position and momentum coordinates respectively.

Then $\frac{dQ}{dt}$ is given by

1. 0

2. $\frac{p^2}{m^2}$

3. $-\frac{p^2}{m^2}$

4. $\frac{qp}{mt}$

Q144. [June 2025] . 5.0 marks

Classical Mechanics > Lagrangian and Hamiltonian

CSIR NET	2025 June	5M	CM
----------	-----------	----	----

A massless rod of length l is hinged at the extreme end of a vertical spring whose other end is fixed to the ground. A point mass m is fixed at end of the rod, as shown in the figure. Assume harmonic motion of the spring given by $h(t) = h_0(2 + \cos\omega t)$, where $h_0 > l$. The equation of motion of the mass (confined to the plane of the figure) is given by

1. $l\ddot{\theta} + \omega^2 h_0 \sin\theta \sin\omega t - g \sin\theta = 0$
2. $l\ddot{\theta} + \omega^2 h_0 \sin\theta \cos\omega t - g \sin\theta = 0$
3. $l\ddot{\theta} + \omega^2 h_0 \sin\theta \cos\omega t + g \sin\theta = 0$
4. $l\ddot{\theta} - \omega^2 h_0 \sin\theta \sin\omega t + g \sin\theta = 0$

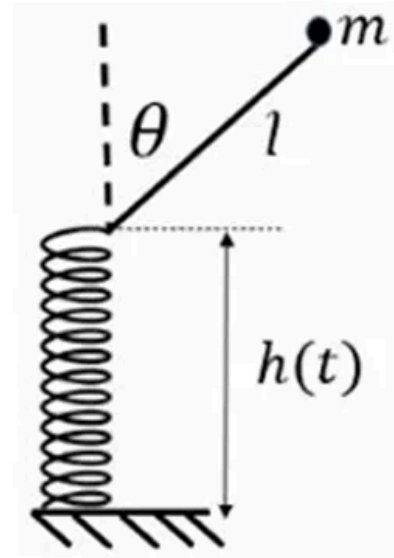

Q145. [June 2025] . 5.0 marks

Classical Mechanics > Special theory of relativity

CSIR NET	2025 June	5M	CM
----------	-----------	----	----

In its rest frame, a source emits light in a conical beam of width -45° to 45° . An observer is moving towards the source with a speed v . For the observer, the beam width appears to be -30° to 30° . The speed of the observer is closest to

Rest frame

- 1. $0.62c$
- 2. $0.50c$
- 3. $0.82c$
- 4. $0.41c$

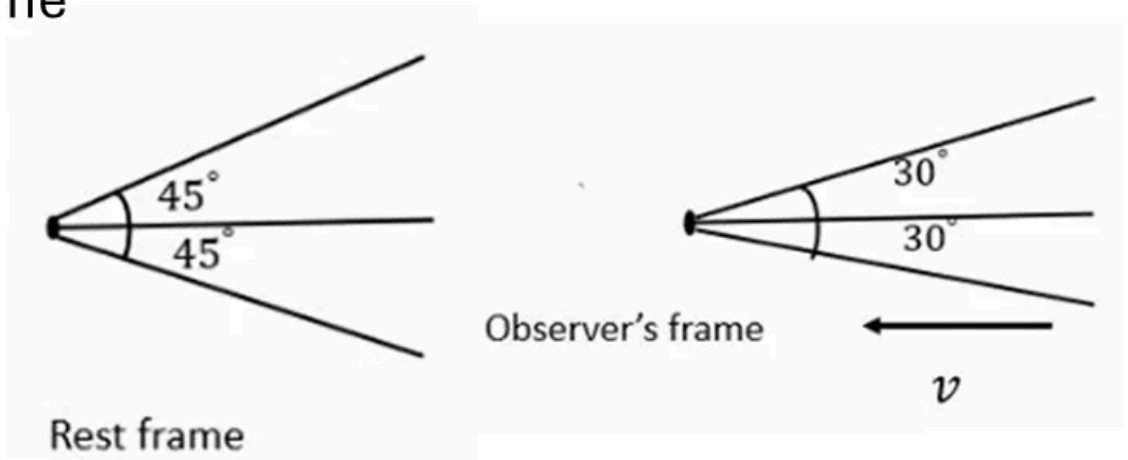

Answer Key

145 questions . Subject and topic for quick revision

Q. No	Subject	Topic	Answer
Q1	Classical Mechanics	Central forces	1
Q2	Classical Mechanics	Rotation Motion	2
Q3	Classical Mechanics	Oscillations	1
Q4	Classical Mechanics	Special theory of relativity	3
Q5	Classical Mechanics	Oscillations	3
Q6	Classical Mechanics	Canonical transformations	4
Q7	Classical Mechanics	Special theory of relativity	2
Q8	Classical Mechanics	Lagrangian and Hamiltonian	4
Q9	Classical Mechanics	Lagrangian and Hamiltonian	3
Q10	Classical Mechanics	Oscillations	2
Q11	Classical Mechanics	Central forces	1
Q12	Classical Mechanics	Special theory of relativity	2
Q13	Classical Mechanics	Canonical transformations	4
Q14	Classical Mechanics	Phase space diagrams	1
Q15	Classical Mechanics	Special theory of relativity	3
Q16	Classical Mechanics	Basic Mechanics	2
Q17	Classical Mechanics	Special theory of relativity	4
Q18	Classical Mechanics	Poisson brackets	1
Q19	Classical Mechanics	Lagrangian and Hamiltonian	4
Q20	Classical Mechanics	Oscillations	2
Q21	Classical Mechanics	Basic Mechanics	1
Q22	Classical Mechanics	Central forces	3
Q23	Classical Mechanics	Special theory of relativity	1
Q24	Classical Mechanics	Special theory of relativity	4
Q25	Classical Mechanics	Basic Mechanics	3
Q26	Classical Mechanics	Lagrangian and Hamiltonian	1
Q27	Classical Mechanics	Special theory of relativity	2
Q28	Classical Mechanics	Canonical transformations	2
Q29	Classical Mechanics	Lagrangian and Hamiltonian	2
Q30	Classical Mechanics	Pseudo Forces	4
Q31	Classical Mechanics	Basic Mechanics	2
Q32	Classical Mechanics	Special theory of relativity	2
Q33	Classical Mechanics	Oscillations	1
Q34	Classical Mechanics	Oscillations	1
Q35	Classical Mechanics	Phase space diagrams	2
Q36	Classical Mechanics	Canonical transformations	None
Q37	Classical Mechanics	Central forces	3
Q38	Classical Mechanics	Special theory of relativity	4
Q39	Classical Mechanics	Lagrangian and Hamiltonian	1
Q40	Classical Mechanics	Special theory of relativity	3

Answer Key (cont.)

Q. No	Subject	Topic	Answer
Q41	Classical Mechanics	Basic Mechanics	3
Q42	Classical Mechanics	Oscillations	1
Q43	Classical Mechanics	Lagrangian and Hamiltonian	3
Q44	Classical Mechanics	Canonical transformations	4
Q45	Classical Mechanics	Lagrangian and Hamiltonian	2
Q46	Classical Mechanics	Basic Mechanics	3
Q47	Classical Mechanics	Central forces	3
Q48	Classical Mechanics	Oscillations	3
Q49	Classical Mechanics	Special theory of relativity	3
Q50	Classical Mechanics	Lagrangian and Hamiltonian	3
Q51	Classical Mechanics	Lagrangian and Hamiltonian	1
Q52	Classical Mechanics	Special theory of relativity	1
Q53	Classical Mechanics	Oscillations	1
Q54	Classical Mechanics	Central forces	3
Q55	Classical Mechanics	Special theory of relativity	2
Q56	Classical Mechanics	Oscillations	3
Q57	Classical Mechanics	Central forces	2
Q58	Classical Mechanics	Lagrangian and Hamiltonian	3
Q59	Classical Mechanics	Special theory of relativity	2
Q60	Classical Mechanics	Special theory of relativity	3
Q61	Classical Mechanics	Basic Mechanics	2
Q62	Classical Mechanics	Phase space diagrams	2
Q63	Classical Mechanics	Lagrangian and Hamiltonian	2
Q64	Classical Mechanics	Canonical transformations	2
Q65	Classical Mechanics	Poisson brackets	1
Q66	Classical Mechanics	Basic Mechanics	2
Q67	Classical Mechanics	Basic Mechanics	1
Q68	Classical Mechanics	Basic Mechanics	3
Q69	Classical Mechanics	Pseudo Forces	4
Q70	Classical Mechanics	Central forces	1
Q71	Classical Mechanics	Oscillations	2
Q72	Classical Mechanics	Basic Mechanics	1
Q73	Classical Mechanics	Lagrangian and Hamiltonian	4
Q74	Classical Mechanics	Basic Mechanics	3
Q75	Classical Mechanics	Special theory of relativity	1
Q76	Classical Mechanics	Oscillations	3
Q77	Classical Mechanics	Lagrangian and Hamiltonian	3
Q78	Classical Mechanics	Oscillations	2
Q79	Classical Mechanics	Special theory of relativity	1
Q80	Classical Mechanics	Rotation Motion	4
Q81	Classical Mechanics	Basic Mechanics	1

Answer Key (cont.)

Q. No	Subject	Topic	Answer
Q82	Classical Mechanics	Basic Mechanics	3
Q83	Classical Mechanics	Oscillations	2
Q84	Classical Mechanics	Phase space diagrams	1
Q85	Classical Mechanics	Oscillations	2
Q86	Classical Mechanics	Central forces	2
Q87	Classical Mechanics	Special theory of relativity	3
Q88	Classical Mechanics	Special theory of relativity	3
Q89	Classical Mechanics	Oscillations	2
Q90	Classical Mechanics	Central forces	2
Q91	Classical Mechanics	Lagrangian and Hamiltonian	None
Q92	Classical Mechanics	Central forces	1
Q93	Classical Mechanics	Oscillations	2
Q94	Classical Mechanics	Lagrangian and Hamiltonian	1
Q95	Classical Mechanics	Central forces	4
Q96	Classical Mechanics	Special theory of relativity	2
Q97	Classical Mechanics	Oscillations	4
Q98	Classical Mechanics	Phase space diagrams	None
Q99	Classical Mechanics	Rotation Motion	3
Q100	Classical Mechanics	Central forces	2
Q101	Classical Mechanics	Lagrangian and Hamiltonian	1
Q102	Classical Mechanics	Oscillations	4
Q103	Classical Mechanics	Special theory of relativity	1
Q104	Classical Mechanics	Central forces	1
Q105	Classical Mechanics	Central forces	1
Q106	Classical Mechanics	Canonical transformations	1
Q107	Classical Mechanics	Lagrangian and Hamiltonian	2
Q108	Classical Mechanics	Lagrangian and Hamiltonian	1
Q109	Classical Mechanics	Central forces	1
Q110	Classical Mechanics	Lagrangian and Hamiltonian	4
Q111	Classical Mechanics	Rotation Motion	3
Q112	Classical Mechanics	Central forces	4
Q113	Classical Mechanics	Oscillations	1
Q114	Classical Mechanics	Canonical transformations	3
Q115	Classical Mechanics	Special theory of relativity	2
Q116	Classical Mechanics	Special theory of relativity	3
Q117	Classical Mechanics	Lagrangian and Hamiltonian	2
Q118	Classical Mechanics	Basic Mechanics	1
Q119	Classical Mechanics	Basic Mechanics	2
Q120	Classical Mechanics	Lagrangian and Hamiltonian	1
Q121	Classical Mechanics	Canonical transformations	4
Q122	Classical Mechanics	Poisson brackets	3

Answer Key (cont.)

Q. No	Subject	Topic	Answer
Q123	Classical Mechanics	Phase space diagrams	1
Q124	Classical Mechanics	Rotation Motion	2
Q125	Classical Mechanics	Central forces	4
Q126	Classical Mechanics	Special theory of relativity	1
Q127	Classical Mechanics	Central forces	4
Q128	Classical Mechanics	Oscillations	3
Q129	Classical Mechanics	Poisson brackets	1
Q130	Classical Mechanics	Oscillations	3
Q131	Classical Mechanics	Rotation Motion	3
Q132	Classical Mechanics	Rotation Motion	2
Q133	Classical Mechanics	Phase space diagrams	4
Q134	Classical Mechanics	Basic Mechanics	2
Q135	Classical Mechanics	Canonical transformations	2
Q136	Classical Mechanics	Special theory of relativity	4
Q137	Classical Mechanics	Oscillations	2
Q138	Classical Mechanics	Lagrangian and Hamiltonian	3
Q139	Classical Mechanics	Basic Mechanics	1
Q140	Classical Mechanics	Basic Mechanics	2
Q141	Classical Mechanics	Lagrangian and Hamiltonian	3
Q142	Classical Mechanics	Rotation Motion	2
Q143	Classical Mechanics	Poisson brackets	1
Q144	Classical Mechanics	Lagrangian and Hamiltonian	2
Q145	Classical Mechanics	Special theory of relativity	4

Study with PhysicsByAaryan

Full CSIR NET / GATE / JEST / BARC Physics live batch by Aaryan Mehra Sir.
Concept-first teaching, complete PYQ coverage, daily doubt support.

Use coupon CONSISTENCY for Rs. 500 off

Visit

www.physicsbyaaryan.com

www.csirnetphysics.com

Contact

9501976811